



EALP Series

LED Outdoor Area Light

The EALP Area Light luminaire offers a wide range of optical patterns, color temperatures, lumen packages and mounting configurations to optimize area light applications, as well as provide versatility in lighting design within one form-factor. They are ideal for commercial property site-lighting applications such as retail and commercial exteriors.



Construction

Housing:	Aluminum die cast enclosure. Integral heat sink for maximum heat transfer
Lens:	Impact resistant tempered glass
Paint:	Corrosion resistant polyester powder paint, minimum 2.0 mil thickness Standard = Black, Dark Bronze Gray, White (RAL & custom colors available) Optional = Coastal Finish
Weight:	27 lbs

Optical system

Lumens:	70,700
Photometry:	Type II, III, IV & V
Efficacy:	132 LPW
CCT:	3000K, 4000K, 5000K
CRI:	≥70
Upward Light Output Ratio (ULOR):	0 Horizontal Orientation

Electrical

Input Voltage:	120-277V, 277-480V & 347-480V
Input Frequency:	50/60 Hz
Power Factor (PH):	≥ 0.9 at rated watts
Total Harmonic Distortion (THD):	≤ 20% at rated watts

Surge Protection

6kV/3kA	10kV/5kA	20kV/10kA
---------	----------	-----------

Per ANSI C136.2-2023



Optical Only

Lumen Maintenance

Projected Lxx per IES TM-21-11 at 25°C

OPTICS	LXX(H0K) @ HOURS		
	25,000 HR	50,000 HR	60,000 HR
M2, M3, M4, M5	L96	L95	L94
N2, N3, N4, N5 P2, P3, P4, P5	L96	L94	L93
R2, R3, R4, R5	L93	L89	L87
P2, P3, P4, P5, Q2, Q3, Q4, Q5	L95	L93	L92

Note: Projected Lxx based on LM80 (= 10,000 hour testing). Accepted industry tolerances apply to initial luminous flux and lumen maintenance measurements

Luminaire Ambient Temperature Factor

AMBIENT TEMP (°C)	INITIAL FLUX FACTOR	AMBIENT TEMP (°C)	INITIAL FLUX FACTOR
10	1.02	30	0.99
20	1.01	40	0.98
25	1.00		

Ratings

Operating Temperature:	-40° C to 50° C Mx Optic Codes are -40° C to 45° C Nx Optic Codes are -40° C to 40° C Px Optic Codes are -40° C to 35° C Rx Optic Codes are -40° C to 30° C
Vibration:	3G per ANSI C136.31-2010
LM-79:	Testing in accordance with IESNA Standards

Controls

Dimming:	Standard - 0-10V Optional - DALI (Option U)
Sensors:	Photo Electric Sensors (PE) available LightGrid+™ and Daintree Compatible

Warranty

5 Year (Standard)

10 Year (Optional)

Ordering Information

EALP 03 7

PRODUCT ID	GENERATION	VOLTAGE	OPTICAL CODE	DISTRIBUTION	CRI	CCT	DIMMING ²	CONTROLS	MOUNTING ARM	COLOR	OPTIONS
E= Evolve AL= Area Light P = Premium	03	0 ¹ =120-277V H ¹ = 347-480V E ¹ = 277-480V 1 = 120V 2 = 208V 3 = 240V 4 = 277V 5 = 480V D = 347V	Mx = 40000 lm Nx = 50000 lm ¹⁴ Px = 60000 lm ¹⁴ Rx = 70000 lm ¹⁴	SM = Symmetric Medium SW = Symmetric Wide SH = Symmetric High Angle AF = Asymmetric Forward AH = Asymmetric High Angle AW = Asymmetric Wide AN = Asymmetric Narrow/Auto	7 = 70 (min)	30 ¹¹ = 3000K 40 = 4000K 50 = 5000K	N = Dimming thru PE receptacle D = External Dimming 18/2 3 ft Cable	A = ANSI C136.41 7-Pin Receptacle D = ANSI C136.417-Pin Receptacle with Shorting Cap E = ANSI C136.41 7-pin with Non-Dimming PE Control	C1 ⁴ = Integral Slipfitter: Standard D1 ^{15, 16} = Universal Mounting Arm: Fitted for round or square pole mounting For 3"-6" OD round poles. For 4.0" min. square poles K1 ^{4e} = Knuckle Slipfitter: For 1.9 in. - 2.3 in OD Tenon S1 ^{4e} = Knuckle Slipfitter: For 2.3 in. - 3.0 in OD Tenon V1 ^{4e} = Knuckle Wall Mount	BLCK = Black DKBZ = Dark Bronze GRAY = Gray WHTE = White	F = Fusing H2 = Daintree enabled motion sensor ^{6, 13, 14} H4 = Motion Sensor (WattStopper) ¹³ J = cUL/Canada L = Tool-Less Entry R = Enhanced Surge Protection (10kV/5kA) S1 = Rotated Left ¹² S2 = Rotated Right ¹² T = Extreme Surge Protection U = DALI Programmable ⁷ VO = 3 Position Terminal Block Y = Coastal Finish ⁹ XXX = Special Options

¹ Not Available with Fusing, Must Choose a Discrete Voltage with "F" Option Code
² Note Standard Dimming is 0-10V
³ Not available in 277-480V
⁴ Supplied with 3ft leads
⁵ Supplied with 16/3 ft Cable
⁶ Restricted Aiming Angle of 0-45°
⁷ Compatible with LightGrid Wireless Control Nodes, Not Compatible with Motion Sensor Control
⁸ Not available in 347V, 480V or 347-480V.
⁹ Only available with K, L & M optics
¹⁰ Recommended for installations within 750 feet from coast. Lead time varies, check with factory.
¹¹ Select 3000K CCT for DarkSky Approved fixtures.
¹² For aimed left or right light distribution orientation, as assembled in manufacturing. Not applicable for Symmetric Distributions
¹³ Not available with Dali
¹⁴ Not available with 20kV/10kA SPD & Fusing (must choose one or the other)
¹⁵ When mounting fixtures at 90 degrees, round pole must be 3.5" OD minimum

CUSTOMER NAME _____

PROJECT NAME _____

DATE _____ TYPE _____

CATALOG NUMBER _____

TYPE	OPTIC CODE	DISTRIBUTION	TYPICAL INITIAL LUMENS		TYPICAL SYSTEM WATTAGE	BUG RATINGS	
			3000K	4000K & 5000K	120-277 & 347-480V	3000K	4000 & 5000K
						B-U-G	B-U-G
TYPE V	M5	Symmetric Medium (SM)	37800	40000	305	B5-U0-G3	B5-U0-G4
	N5	Symmetric Medium (SM)	47200	50000	400	B5-U0-G4	B5-U0-G4
	P5	Symmetric Medium (SM)	56700	60000	470	B5-U0-G4	B5-U0-G4
	R5	Symmetric Medium (SM)	66100	70000	550	B5-U0-G5	B5-U0-G5
	M5	Symmetric Wide (SW)	37800	40000	305	B5-U0-G2	B5-U0-G2
	N5	Symmetric Wide (SW)	47200	50000	400	B5-U0-G3	B5-U0-G3
	P5	Symmetric Wide (SW)	56700	60000	470	B5-U0-G3	B5-U0-G3
	R5	Symmetric Wide (SW)	66100	70000	550	B5-U0-G4	B5-U0-G4
	M5	Symmetric High Angle (SH)	36400	38600	305	B5-U0-G4	B5-U0-G4
	N5	Symmetric High Angle (SH)	45600	48300	400	B5-U0-G4	B5-U0-G5
	P5	Symmetric High Angle (SH)	54800	58000	470	B5-U0-G5	B5-U0-G5
R5	Symmetric High Angle (SH)	63800	67600	550	B5-U0-G5	B5-U0-G5	
TYPE IV	M4	Asymmetric Forward (AF)	37800	40000	305	B4-U0-G4	B4-U0-G5
	N4	Asymmetric Forward (AF)	47200	50000	400	B4-U0-G5	B4-U0-G5
	P4	Asymmetric Forward (AF)	56700	60000	470	B4-U0-G5	B4-U0-G5
	R4	Asymmetric Forward (AF)	66100	70000	550	B4-U0-G5	B4-U0-G5
	M4	Asymmetric High Angle (AH)	36400	38600	305	B4-U0-G5	B4-U0-G5
	N4	Asymmetric High Angle (AH)	45600	48300	400	B4-U0-G5	B4-U0-G5
	P4	Asymmetric High Angle (AH)	54800	58000	470	B4-U0-G5	B4-U0-G5
	R4	Asymmetric High Angle (AH)	63800	67600	550	B5-U0-G5	B5-U0-G5
TYPE III	M3	Asymmetric Wide (AW)	37800	40000	305	B4-U0-G3	B4-U0-G4
	N3	Asymmetric Wide (AW)	47200	50000	400	B4-U0-G4	B4-U0-G4
	P3	Asymmetric Wide (AW)	56700	60000	470	B5-U0-G4	B5-U0-G4
	R3	Asymmetric Wide (AW)	66100	70000	550	B5-U0-G5	B5-U0-G5
TYPE II	M2	Asymmetric Narrow/Auto (AN)	38100	40400	305	B4-U0-G4	B4-U0-G4
	N2	Asymmetric Narrow/Auto (AN)	47700	50500	400	B4-U0-G4	B4-U0-G4
	P2	Asymmetric Narrow/Auto (AN)	57200	60600	470	B4-U0-G4	B4-U0-G4
	R2	Asymmetric Narrow/Auto (AN)	66800	70700	550	B5-U0-G5	B5-U0-G5

EALP03
ASYMMETRIC NARROW
(R2AN750)
70700 Lumens
5000k
EALP03_Q2AN750_____IES

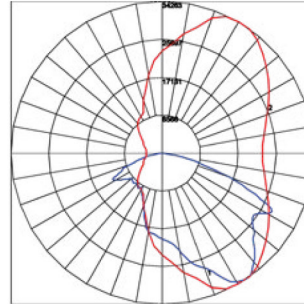
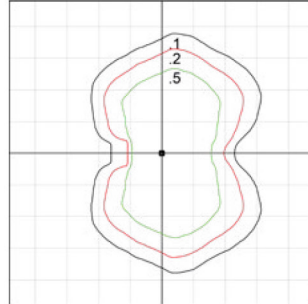

Gridline spacing is equal to mounting height. Initial footcandle values shown are at grade for 40' mounting height.

—: Vertical plane through horizontal angle of maximum candlepower at 60°
—: Vertical plane through horizontal angle 35°

EALP03
ASYMMETRIC WIDE
(R3AW750)
70000 Lumens
5000k
EALP03_Q3AW750_____IES

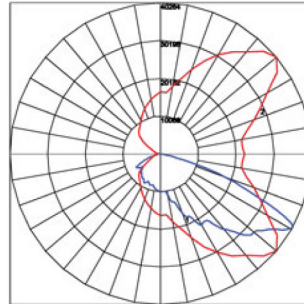
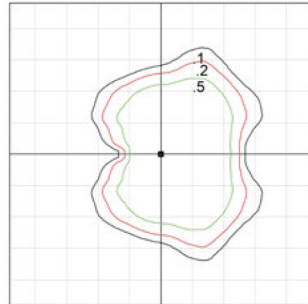

Gridline spacing is equal to mounting height. Initial footcandle values shown are at grade for 40' mounting height.

—: Vertical plane through horizontal angle of maximum candlepower at 40°
—: Vertical plane through horizontal angle 61°

EALP03
ASYMMETRIC FORWARD
(R4AF750)
70000 Lumens
5000k
EALP03_Q4AF750_____IES

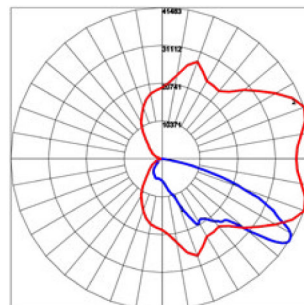
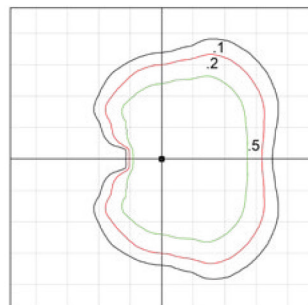

Gridline spacing is equal to mounting height. Initial footcandle values shown are at grade for 40' mounting height.

—: Vertical plane through horizontal angle of maximum candlepower at 20°
—: Vertical plane through horizontal angle 57°

EALP03
ASYMMETRIC FORWARD HIGH ANGLE
(R4AH750)
67600 Lumens
5000k
EALP03_Q4AH750_____IES

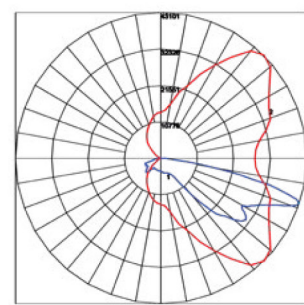
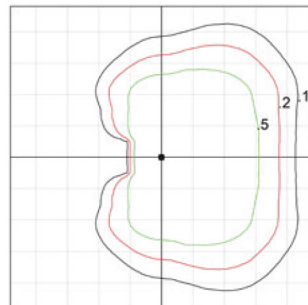

Gridline spacing is equal to mounting height. Initial footcandle values shown are at grade for 40' mounting height.

—: Vertical plane through horizontal angle of maximum candlepower at 45°
—: Vertical plane through horizontal angle 72°

EALP03
SYMMETRIC HIGH ANGLE
(R5SH750)
67600 Lumens
5000k
EALP03_Q5SH750_____IES

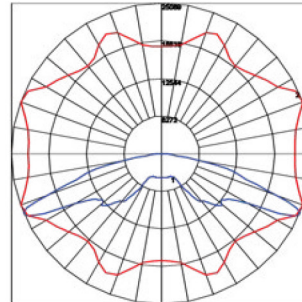
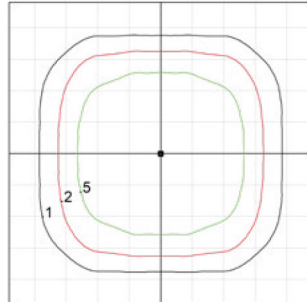

Gridline spacing is equal to mounting height. Initial footcandle values shown are at grade for 40' mounting height.

—: Vertical plane through horizontal angle of maximum candlepower at 20°
—: Vertical plane through horizontal angle 66°

EALP03
SYMMETRIC MEDIUM
(R5SM750)
70000 Lumens
5000k
EALP03_Q5SM750_____IES

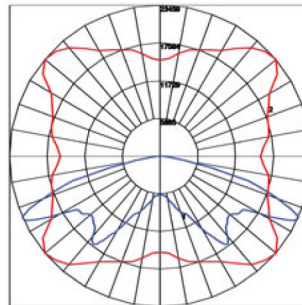
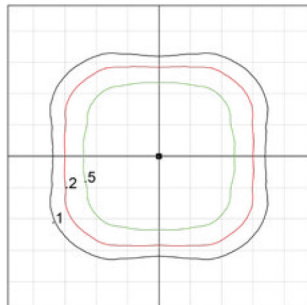

Gridline spacing is equal to mounting height. Initial footcandle values shown are at grade for 40' mounting height.

—: Vertical plane through horizontal angle of maximum candlepower at 40°
—: Vertical plane through horizontal angle 65°

EALP03
SYMMETRIC WIDE
(R5SW750)
70000 Lumens
5000k
EALP03_Q5SW750_____IES

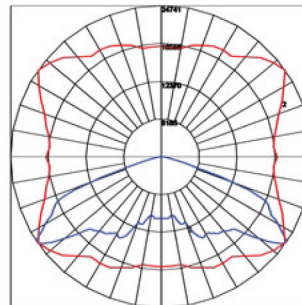
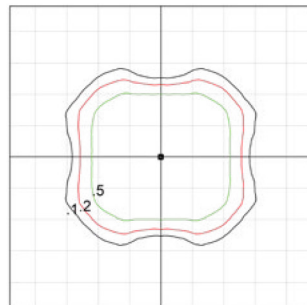

Gridline spacing is equal to mounting height. Initial footcandle values shown are at grade for 40' mounting height.

—: Vertical plane through horizontal angle of maximum candlepower at 35°
—: Vertical plane through horizontal angle 56°

H4 - Motion Sensing Option (WattStopper)

- Recommended Mounting Height: 15-30' (4.6-9.1m)
- For mounting heights exceeding 30 ft., pole mounted sensors are recommended
- Coverage Radius: 15-20' (4.6-6.1 m).
- Provides 270 degree of coverage (approx 90 is blocked by the pole)
- Default Settings:
 - Output Occupied – 100% / Unoccupied – 10%
 - PE Sensor: Disabled
 - Ramp/Fade: Disabled
- Adds < 1W to fixture power rating
- Field programmable using FSIR-100 hand held programmer

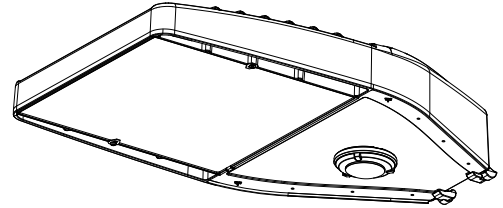

H4 (WattStopper)

H2 - Motion Sensing Option (Daintree WHS-100)

- Recommended Mounting Height: 15-30' (4.6-9.1m)
- For mounting heights exceeding 30 ft., pole mounted sensors are recommended
- Provides a coverage area radius for walking motion of 15-20 ft. (4.57-6.10m)
- Provides 270 degree of coverage (approx 90 is blocked by the pole)
- Default Settings:
 - Output: Occupied - 100%/Unoccupied - 50%
 - PE Sensor: None
 - Ramp/Fade: 5 Minutes/5 Minutes
- Adds < 1W to fixture power rating
- Requires Daintree Enterprise and wide area control (WAC)

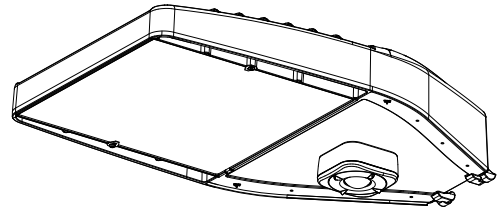

H2 (Daintree)

KNUCKLE SLIPFITTER: S1

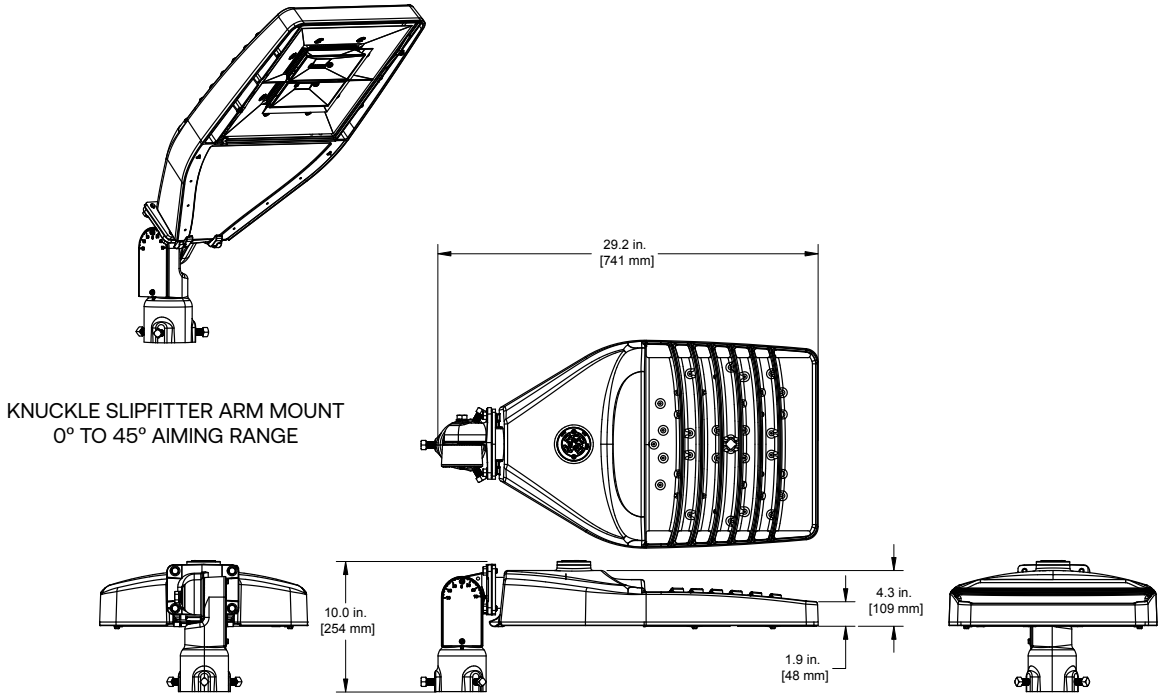

INTEGRAL SLIPFITTER: C1

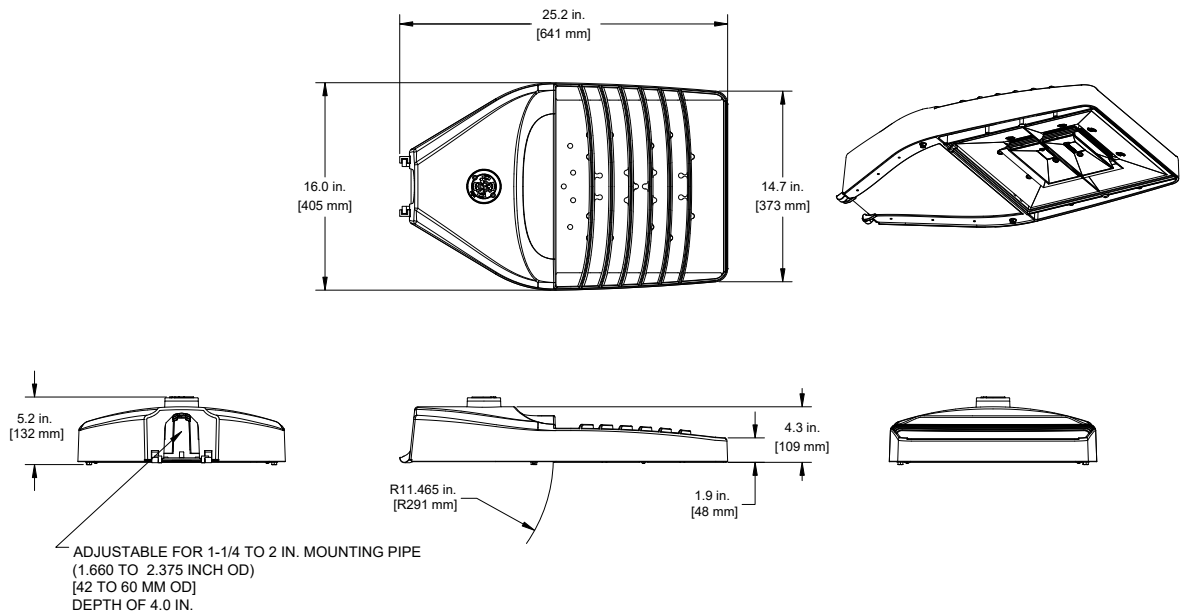

UNIVERSAL ARM MOUNT: D1

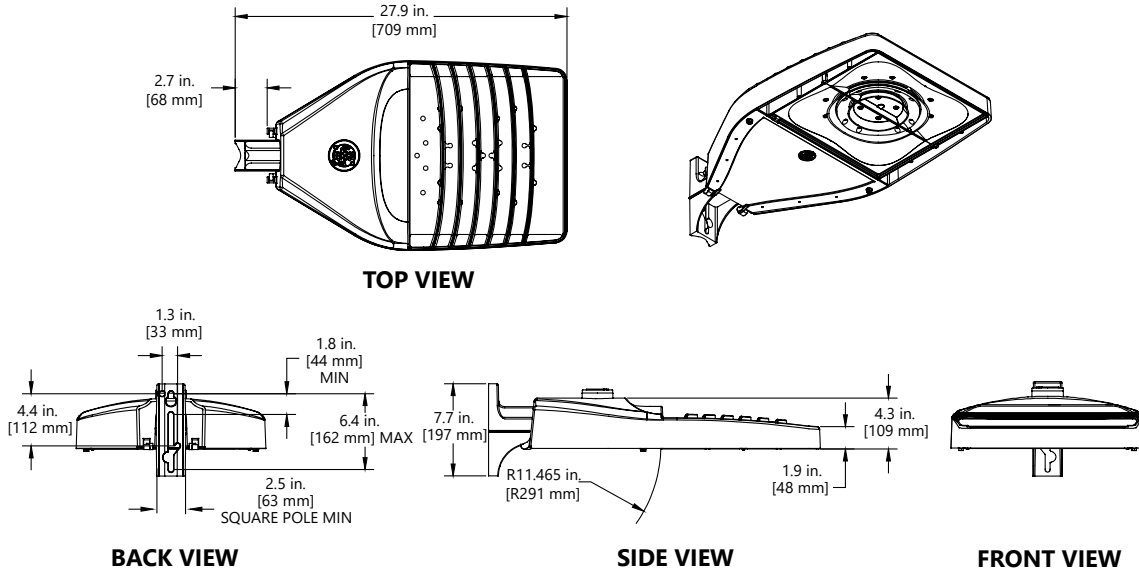

KNUCKLE WALL MOUNT: V1

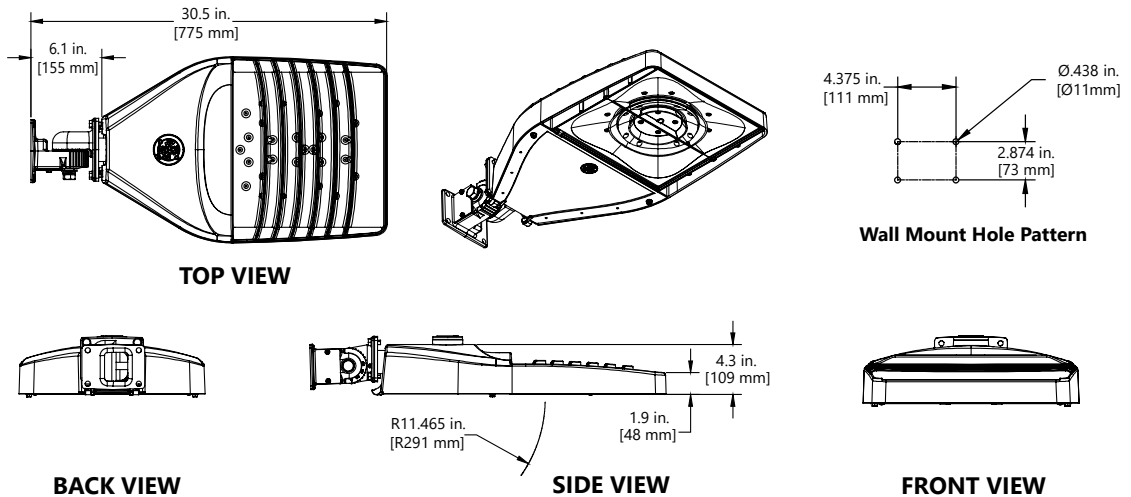

DATA

- Approximate Net Weight: 26-28 lbs (11.79 kgs-12.97 kgs)
- Effective Projected Area (EPA):
 - Knuckle Slipfitter K1, S1, V1 aimed at 45°: EPA = 2.45 sq ft
 - Knuckle w/Slipfitter K1, S1, V1 aimed at 0° downward: EPA = 0.79 sq ft
 - Universal Arm Mount D1: EPA = 0.63 sq ft
 - Integral Slipfitter C1: EPA = 0.55 sq ft

Mounting Arms for Slipfitter

Order separately with Mounting Option C1 (Slipfitter)

SQUARE POLE MOUNTING ARM

4.0 inch (102mm) SQUARE
(WILL ALLOW 4 FIXTURES PER POLE @ 90 DEGREES.)

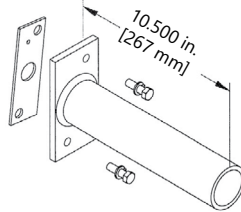

ORDER SEPARATELY FROM FIXTURE AS CATALOG NUMBER
SPA-EAMT10BLCK "Black"
SPA-EAMT10DKBZ "Dark Bronze"

SQUARE POLE MOUNTING DRILLING TEMPLATE

Compatible with E2 Evolve Drill Pattern

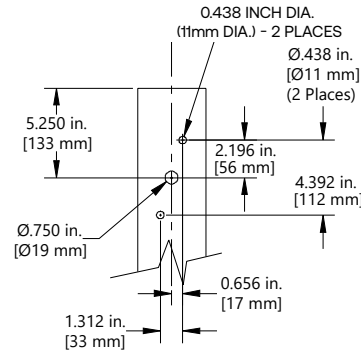

ROUND POLE MOUNTING ARM

3.5 TO 4.5-inch (89 to 114mm) OD
(WILL ALLOW 4 FIXTURES PER POLE @ 90 DEGREES.)

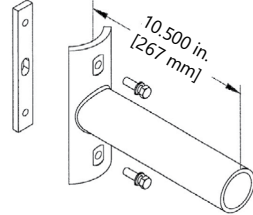

ORDER SEPARATELY FROM FIXTURE AS CATALOG NUMBER
RPA-EAMT10BLCK "Black"
RPA-EAMT10DKBZ "Dark Bronze"

ROUND POLE MOUNTING DRILLING TEMPLATE

Compatible with E1 Evolve Drill Pattern

3.5 TO 4.5-inch (89 to 114mm) OD
round pole mounting arm

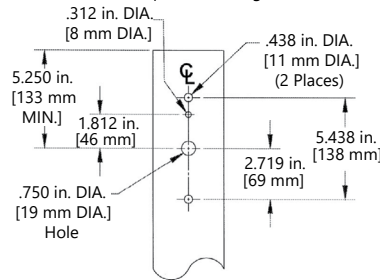

Wall Mounting Bracket Adapter Plate

Order Separately from fixture as catalog number
WMB-EAMT06

*Note: For wall Mounting, order luminaire with mounting arm:
C1 = Slipfitter 2" Pip (2.378 in. OD) supplied with leads.

**Other mounting patterns are available for retrofit installations.
Contact manufacturing for other available mounting patterns.**

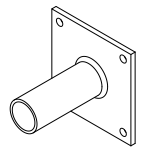
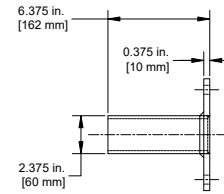
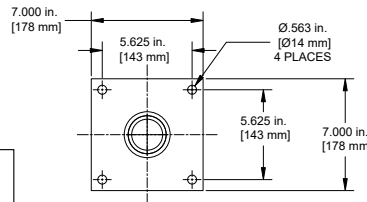

SAP NUMBER	PART NUMBER	DESCRIPTION
93029237G	PED-MV-LED-7	ANSI C136.41 Dimming PE, 120-277V
93029238G	PED-347-LED-7	ANSI C136-41 Dimming PE, 347V
93029239G	PED-480-LED-7	ANSI C136-41 Dimming PE, 480V
28299	PECOTL	Long Life PE 120-277V
93147530	PECHTL	Long Life PE 120-480V
73271	SCCL-PECTL	Shorting Cap

PE Accessories (to be ordered separately)