

Features

- Hot-plugging Protection
- Parallel LED Protection
- Adjustable Output Current (AOC) with Programmability
- Isolated 0-10V/PWM/Resistor Dimmable/3-Timer-Modes Dimmable
- Adjustable Dimming Curve
- INV Digital Dimming, UART Based Communication Protocol
- Dim-to-Off with Standby Power $\leq 0.5W$
- Minimum Dimming Level with 5% or 10% Selectable
- Hold Time Adjustable
- Fade Time Adjustable
- Always-on Auxiliary Power: 12Vdc, 250mA
- Low Inrush Current
- Output Lumen Compensation
- End-of-Life Indicator
- Input Surge Protection: DM 6kV, CM 10kV
- All-Around Protection: IOVP, IUVP, OVP, SCP, OTP
- IP66/IP67 and UL Dry/Damp/Wet Location
- TYPE HL, for use in a Class I, Division 2 Hazardous (Classified) Location
- 5 Years Warranty



Description

The EUM-480SxxxMx series is a 480W, constant-current, programmable and IP66/IP67 rated LED driver that operates from 90-305Vac input with excellent power factor. Created for many lighting applications including high mast, sports, UV-LED, aquaculture and horticulture, etc. It provides an auxiliary voltage and dim-to-off functionality for powering low voltage, wireless controls. The dimming control supports 0-10V dimming as well as two-way communication via Digital Dimming, a UART based communication protocol. The high efficiency of these drivers and compact metal case enables them to run cooler, significantly improving reliability and extending product life. To ensure trouble-free operation, protection is provided against input surge, input under voltage, input over voltage, output over voltage, short circuit, and over temperature.

Models

Adjustable Output Current Range(A)	Full-Power Current Range(A) ⁽¹⁾	Default Output Current(A)	Output Voltage Range(Vdc)	Max. Output Power(W)	Typical Efficiency ⁽²⁾	Typical Power Factor		Model Number ⁽³⁾⁽⁴⁾
						120Vac	220Vac	
0.105-1.4	1.05-1.4	1.4	171-457	480	94.5%	0.99	0.96	EUM-480S140Mx
0.21-2.8	2.1-2.8	2.8	86-228	480	94.0%	0.99	0.96	EUM-480S280Mx
0.315-4.2	3.15-4.2	4.2	57-152	480	94.0%	0.99	0.96	EUM-480S420Mx
0.435-5.6	4.35-5.6	5.6	43-110	480	94.0%	0.99	0.96	EUM-480S560Mx ⁽⁵⁾
0.86-10	8.6-10	10	24-56	480	94.0%	0.99	0.96	EUM-480S10AMx ⁽⁵⁾

- Notes:** (1) Output current range with constant power at 480W.
 (2) Measured at 100% load and 220Vac input (see below "General Specifications" for details).
 (3) Certified input voltage range: UL, FCC 100-277Vac; otherwise 100-240Vac.
 (4) x = G are UL Recognized, ENEC and CCC, etc. models; x = T are UL Class P models.

(5) SELV output.

I-V Operating Area

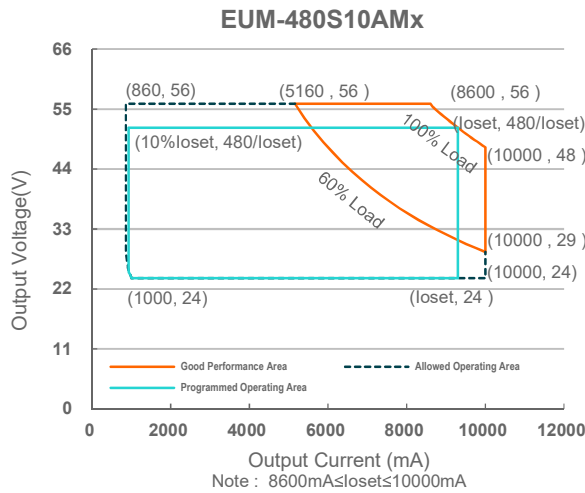
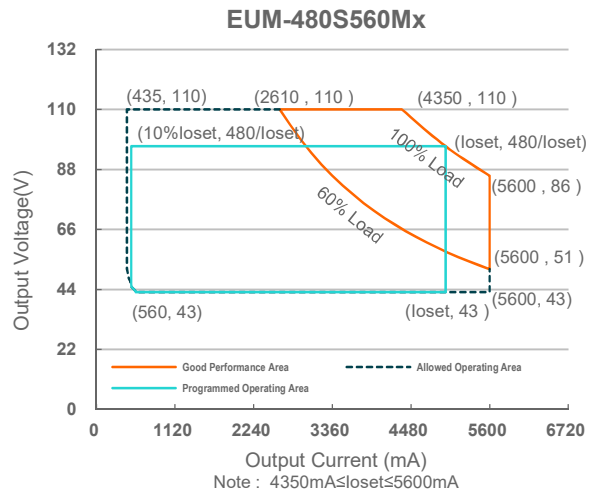
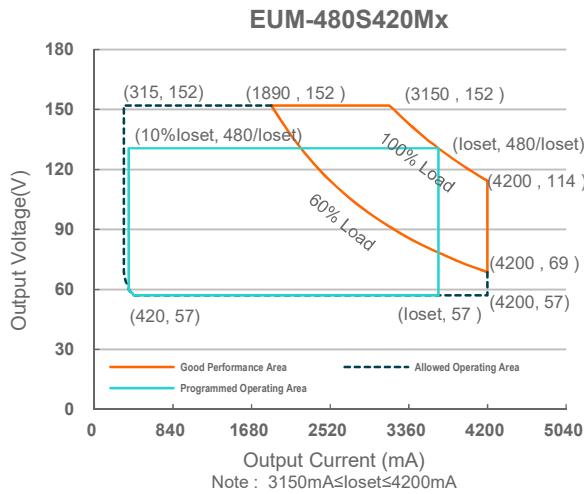
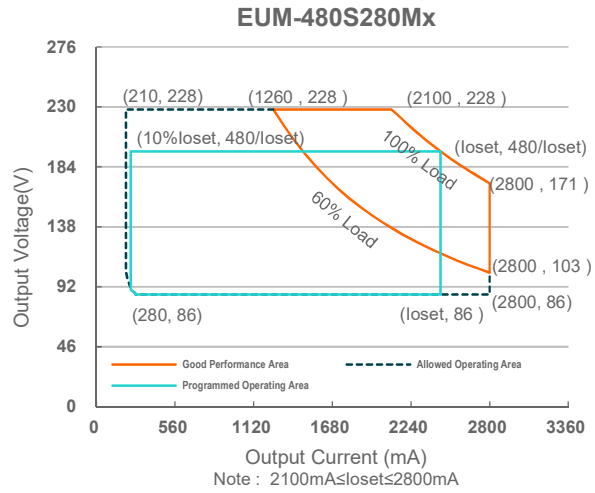
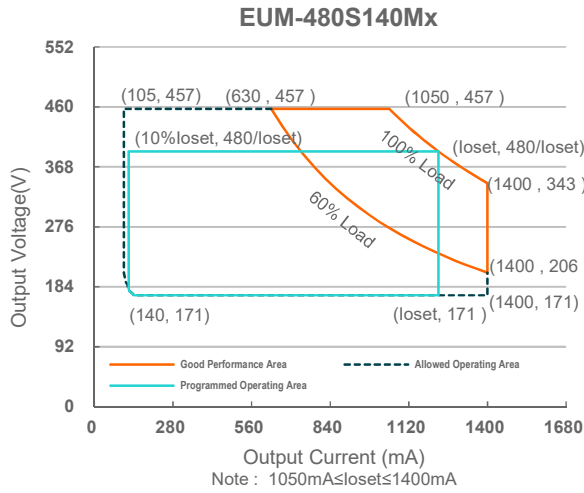

Input Specifications

Parameter	Min.	Typ.	Max.	Notes
Input AC Voltage	90 Vac	-	305 Vac	
Input DC Voltage	127 Vdc	-	250 Vdc	
Input Frequency	47 Hz	-	63 Hz	
Leakage Current	-	-	0.75 MIU	UL 8750; 277Vac/ 60Hz
	-	-	0.70 mA	IEC 60598-1; 240Vac/ 60Hz
Input AC Current	-	-	4.82 A	Measured at 100% load and 120 Vac input.
	-	-	2.61 A	Measured at 100% load and 220 Vac input.
Inrush Current(I ² t)	-	-	1.03 A ² s	At 220Vac input, 25°C cold start, duration=6.52ms, 10%Ipk-10%Ipk.
PF	0.90	-	-	At 100-277Vac, 50-60Hz, 60%-100% Load (288- 480W)
THD	-	-	20%	
THD	-	-	10%	At 220-240Vac, 50-60Hz, 75%-100% Load (360-480W)

Output Specifications

Parameter	Min.	Typ.	Max.	Notes
Output Current Tolerance	-5%loset	-	5%loset	100% load
Output Current Setting(loset) Range				
EUM-480S140Mx	105 mA	-	1400 mA	
EUM-480S280Mx	210 mA	-	2800 mA	
EUM-480S420Mx	315 mA	-	4200 mA	
EUM-480S560Mx	435 mA	-	5600 mA	
EUM-480S10AMx	860 mA	-	10000 mA	
Output Current Setting Range with Constant Power				
EUM-480S140Mx	1050 mA	-	1400 mA	
EUM-480S280Mx	2100 mA	-	2800 mA	
EUM-480S420Mx	3150 mA	-	4200 mA	
EUM-480S560Mx	4350 mA	-	5600 mA	
EUM-480S10AMx	8600 mA	-	10000 mA	
Total Output Current Ripple (pk-pk)	-	5%lomax	10%lomax	100% load, 20 MHz BW
Output Current Ripple at < 200 Hz (pk-pk)	-	2%lomax	-	100% load
Startup Overshoot Current	-	-	10%lomax	100% load
No Load Output Voltage				
EUM-480S140Mx	-	-	500 V	
EUM-480S280Mx	-	-	280 V	
EUM-480S420Mx	-	-	190 V	
EUM-480S560Mx	-	-	120 V	
EUM-480S10AMx	-	-	60 V	
Line Regulation	-	-	±0.5%	100% load
Load Regulation	-	-	±1.5%	

Output Specifications (Continued)

Parameter	Min.	Typ.	Max.	Notes
Turn-on Delay Time	-	-	0.5 s	Measured at 120-277Vac input, 60%-100% Load
Temperature Coefficient of I _o set	-	0.03%/°C	-	Case temperature = 0°C ~T _c max
12V Auxiliary Output Voltage	10.8 V	12 V	13.2 V	
12V Auxiliary Output Source Current	0 mA	-	250 mA	Return terminal is "Dim-"
12V Auxiliary Output Transient Peak Current@ 6W	-	-	500 mA	500mA peak for a maximum duration of 2.2ms in a 6.0ms period during which time the average should not exceed 250mA.
12V Auxiliary Output Transient Peak Current@10W	-	-	850 mA	850mA peak for a maximum duration of 1.3 ms in a 5.2ms period during which time the average should not exceed 250mA.

General Specifications

Parameter	Min.	Typ.	Max.	Notes
Efficiency at 120 Vac input:				
EUM-480S140Mx				
I _o = 1050 mA	90.5%	92.5%	-	
I _o = 1400 mA	91.0%	93.0%	-	
EUM-480S280Mx				
I _o = 2100 mA	90.5%	92.5%	-	
I _o = 2800 mA	90.5%	92.5%	-	
EUM-480S420Mx				
I _o = 3150 mA	90.5%	92.5%	-	
I _o = 4200 mA	90.0%	92.0%	-	
EUM-480S560Mx				
I _o = 4350 mA	90.0%	92.0%	-	
I _o = 5600 mA	90.5%	92.5%	-	
EUM-480S10AMx				
I _o = 8600 mA	90.5%	92.5%	-	
I _o = 10000 mA	90.0%	92.0%	-	
Efficiency at 220 Vac input:				
EUM-480S140Mx				
I _o = 1050 mA	92.5%	94.5%	-	
I _o = 1400 mA	92.5%	94.5%	-	
EUM-480S280Mx				
I _o = 2100 mA	92.0%	94.0%	-	
I _o = 2800 mA	92.0%	94.0%	-	
EUM-480S420Mx				
I _o = 3150 mA	92.0%	94.0%	-	
I _o = 4200 mA	92.0%	94.0%	-	
EUM-480S560Mx				
I _o = 4350 mA	92.0%	94.0%	-	
I _o = 5600 mA	92.0%	94.0%	-	
EUM-480S10AMx				
I _o = 8600 mA	92.0%	94.0%	-	
I _o = 10000 mA	92.0%	94.0%	-	

General Specifications (Continued)

Parameter	Min.	Typ.	Max.	Notes
Efficiency at 277 Vac input: EUM-480S140Mx				Measured at 100% load and steady-state temperature in 25°C ambient; (Efficiency will be about 2.0% lower if measured immediately after startup.)
Io= 1050 mA	93.0%	95.0%	-	
Io= 1400 mA	93.0%	95.0%	-	
EUM-480S280Mx				
Io= 2100 mA	92.5%	94.5%	-	
Io= 2800 mA	92.5%	94.5%	-	
EUM-480S420Mx				
Io= 3150 mA	92.5%	94.5%	-	
Io= 4200 mA	92.0%	94.0%	-	
EUM-480S560Mx				
Io= 4350 mA	92.0%	94.0%	-	
Io= 5600 mA	92.0%	94.0%	-	
EUM-480S10AMx				
Io= 8600 mA	92.0%	94.0%	-	
Io= 10000 mA	92.5%	94.5%	-	
Standby Power	-	-	0.5 W	Measured at 230Vac/50Hz; Dimming off
MTBF	-	293,000 Hours	-	Measured at 220Vac input, 80%Load and 25°C ambient temperature (MIL-HDBK-217F)
Lifetime	-	102,000 Hours	-	Measured at 220Vac input, 80%Load and 70°C case temperature; See lifetime vs. Tc curve for the details
	-	107,000 Hours	-	Measured at 220Vac input, 100%Load and 40°C ambient temperature
Operating Case Temperature for Safety Tc_s	-40°C	-	+90°C	
Operating Case Temperature for Warranty Tc_w	-40°C	-	+80°C	Case temperature for 5 years warranty Humidity: 10%RH to 95%RH
Storage Temperature	-40°C	-	+85°C	Humidity: 5%RH to 95%RH
Dimensions				With mounting ear
Inches (L × W × H)	9.57 × 3.54 × 1.71			10.31 × 3.54 × 1.71
Millimeters (L × W × H)	243 × 90 × 43.5			262 × 90 × 43.5
Net Weight	-	1864 g	-	

Dimming Specifications

Parameter	Min.	Typ.	Max.	Notes	
Absolute Maximum Voltage on the Vdim (+) Pin	-20 V	-	20 V		
Source Current on Vdim (+)Pin	90 uA	100 uA	110 uA	Vdim(+) = 0 V	
Dimming Output Range with 10%-100% (Default)	EUM-480S140Mx EUM-480S280Mx EUM-480S420Mx EUM-480S560Mx EUM-480S10AMx	10%I _o set	-	I _o set	1050 mA ≤ I _o set ≤ 1400 mA 2100 mA ≤ I _o set ≤ 2800 mA 3150 mA ≤ I _o set ≤ 4200 mA 4350 mA ≤ I _o set ≤ 5600 mA 8600 mA ≤ I _o set ≤ 10000 mA
	EUM-480S140Mx EUM-480S280Mx EUM-480S420Mx EUM-480S560Mx EUM-480S10AMx	105 mA 210 mA 315 mA 435 mA 860 mA	-	I _o set	105 mA ≤ I _o set < 1050 mA 210 mA ≤ I _o set < 2100 mA 315 mA ≤ I _o set < 3150 mA 435 mA ≤ I _o set < 4350 mA 860 mA ≤ I _o set < 8600 mA

Dimming Specifications (Continued)

Parameter		Min.	Typ.	Max.	Notes
Dimming Output Range with 5%-100% (Settable)	EUM-480S140Mx EUM-480S280Mx EUM-480S420Mx EUM-480S560Mx EUM-480S10AMx	5% <i>I</i> _{load}	-	<i>I</i> _{load}	1050 mA ≤ <i>I</i> _{load} ≤ 1400 mA 2100 mA ≤ <i>I</i> _{load} ≤ 2800 mA 3150 mA ≤ <i>I</i> _{load} ≤ 4200 mA 4350 mA ≤ <i>I</i> _{load} ≤ 5600 mA 8600 mA ≤ <i>I</i> _{load} ≤ 10000 mA
	EUM-480S140Mx EUM-480S280Mx EUM-480S420Mx EUM-480S560Mx EUM-480S10AMx	53 mA 105 mA 158 mA 218 mA 430 mA	-	<i>I</i> _{load}	105 mA ≤ <i>I</i> _{load} < 1050 mA 210 mA ≤ <i>I</i> _{load} < 2100 mA 315 mA ≤ <i>I</i> _{load} < 3150 mA 435 mA ≤ <i>I</i> _{load} < 4350 mA 860 mA ≤ <i>I</i> _{load} < 8600 mA
Recommended Dimming Input Range		0 V	-	10 V	Default 0-10V dimming mode.
Dim off Voltage		0.35 V	0.5 V	0.65 V	
Dim on Voltage		0.55 V	0.7 V	0.85 V	
Hysteresis		-	0.2 V	-	
PWM_in High Level		3 V	-	10 V	Dimming mode set to PWM in Inventronics Programing Software.
PWM_in Low Level		-0.3 V	-	0.6 V	
PWM_in Frequency Range		200 Hz	-	3 KHz	
PWM_in Duty Cycle		1%	-	99%	
PWM Dimming off (Positive Logic)		3%	5%	8%	
PWM Dimming on (Positive Logic)		5%	7%	10%	
PWM Dimming off (Negative Logic)		92%	95%	97%	
PWM Dimming on (Negative Logic)		90%	93%	95%	
Hysteresis		-	2%	-	

Safety & EMC Compliance

Safety Category	Standard
UL/CUL	UL 8750,CAN/CSA-C22.2 No. 250.13
ENEC & CE	EN 61347-1, EN 61347-2-13
UKCA	BS EN 61347-1, BS EN 61347-2-13
CB	IEC 61347-1, IEC 61347-2-13
CCC	GB 19510.1, GB 19510.14
KC	KC 61347-1, KC 61347-2-13
EAC	TP TC 004, TP TC 020
global-mark	AS/NZS 61347.1, AS/NZS 61347.2.13
Performance	Standard
ENEC	EN 62384

Safety & EMC Compliance (Continued)

EMI Standards	Notes
BS EN/EN IEC 55015/GB/T 17743/KS C 9815 ⁽¹⁾	Conducted emission Test & Radiated emission Test
BS EN/EN IEC 61000-3-2/GB 17625.1	Harmonic current emissions
BS EN/EN 61000-3-3	Voltage fluctuations & flicker
FCC Part 15 ⁽¹⁾	ANSI C63.4 Class B
	This device complies with Part 15 of the FCC Rules. Operation is subject to the following two conditions: [1] this device may not cause harmful interference, and [2] this device must accept any interference received, including interference that may cause undesired Operation.
EMS Standards	Notes
BS EN/EN 61000-4-2	Electrostatic Discharge (ESD): 8 kV air discharge, 4 kV contact discharge
BS EN/EN 61000-4-3	Radio-Frequency Electromagnetic Field Susceptibility Test-RS
BS EN/EN 61000-4-4	Electrical Fast Transient / Burst-EFT
BS EN/EN 61000-4-5	Surge Immunity Test: AC Power Line: Differential Mode 6 kV, Common Mode 10 kV
BS EN/EN 61000-4-6	Conducted Radio Frequency Disturbances Test-CS
BS EN/EN 61000-4-8	Power Frequency Magnetic Field Test
BS EN/EN 61000-4-11	Voltage Dips
BS EN/EN 61547/KS C 9547	Electromagnetic Immunity Requirements Applies To Lighting Equipment

Note: (1) This LED driver meets the EMI specifications above, but EMI performance of a luminaire that contains it depends also on the other devices connected to the driver and on the fixture itself.

Derating

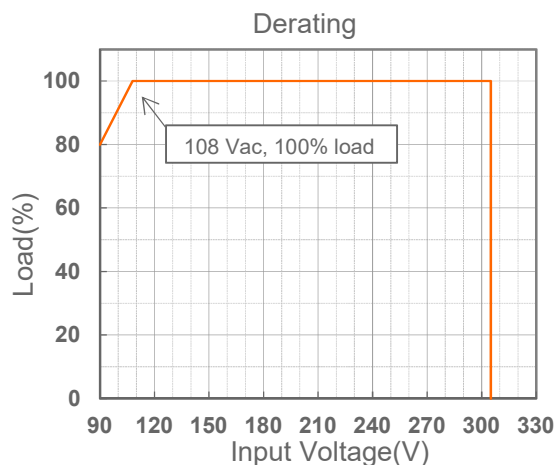

Lifetime vs. Case Temperature

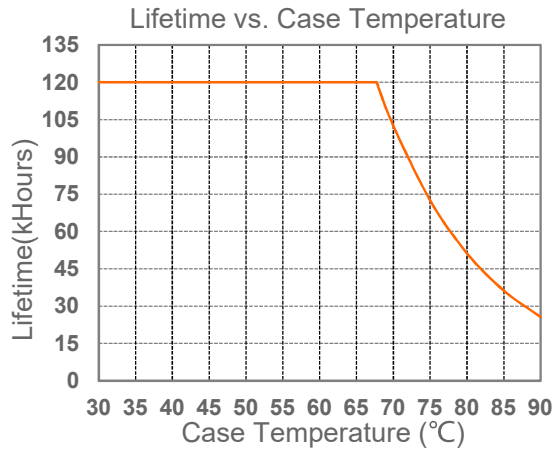

Inrush Current Waveform

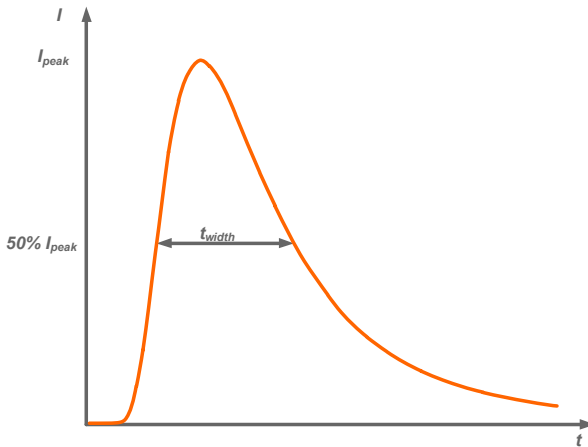

Input AC Voltage	I_{peak}	t_{width} (@ 50% I_{peak})
220Vac	14.5A	2.0ms

Efficiency vs. Load

EUM-480S140Mx($I_o=1050mA$)
Efficiency vs. Output Voltage

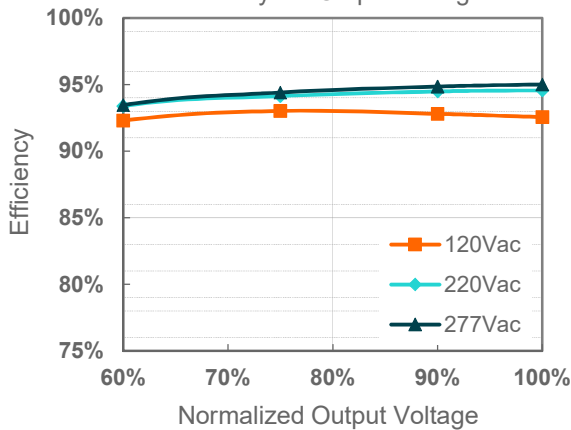

EUM-480S140Mx($I_o=1400mA$)
Efficiency vs. Output Voltage

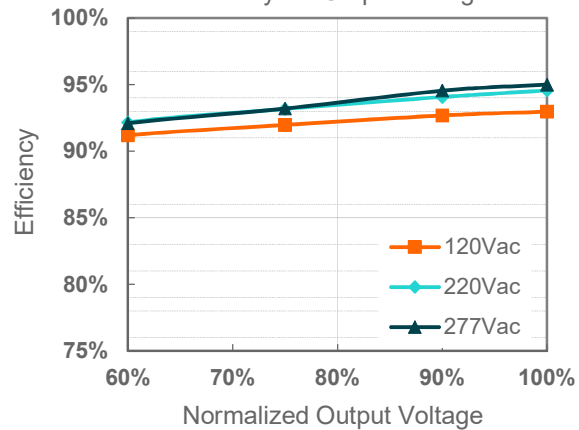

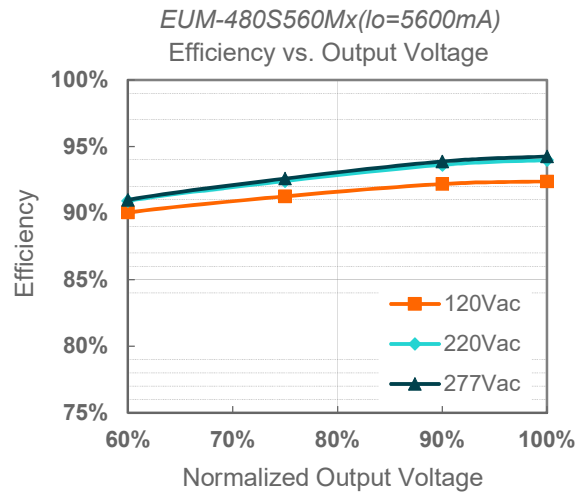
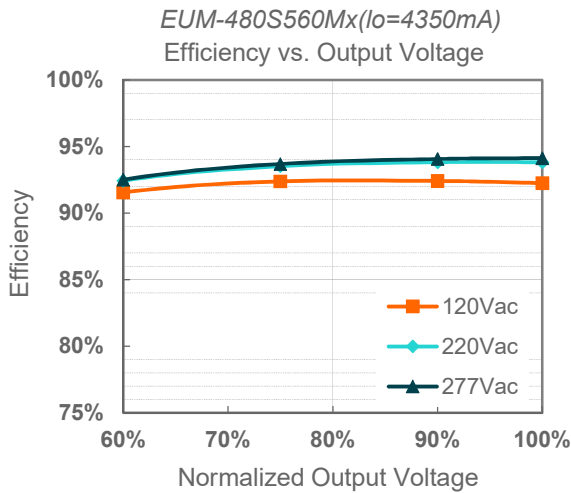
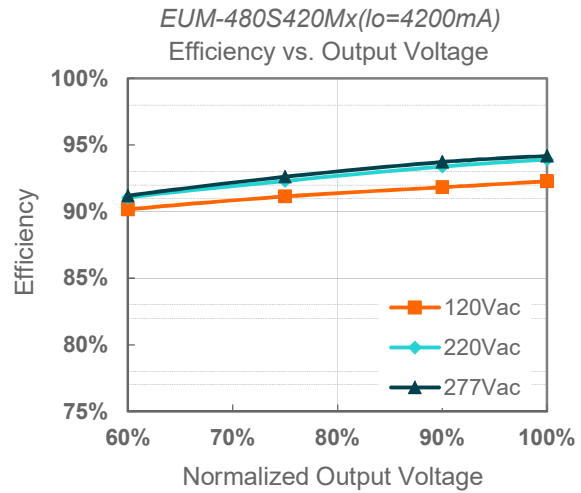
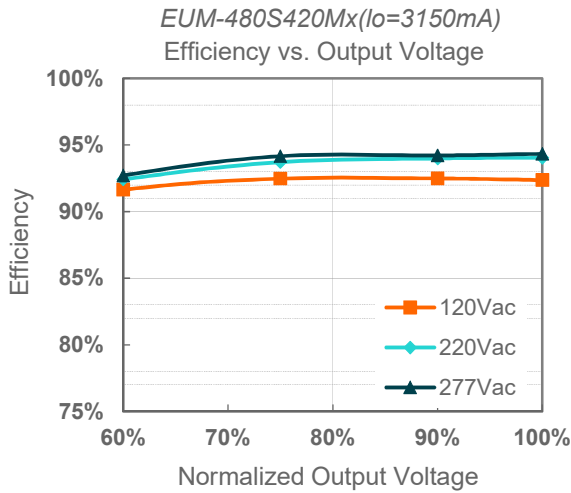
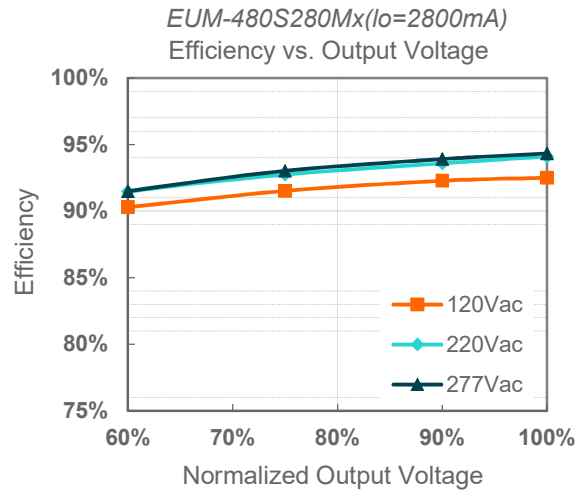
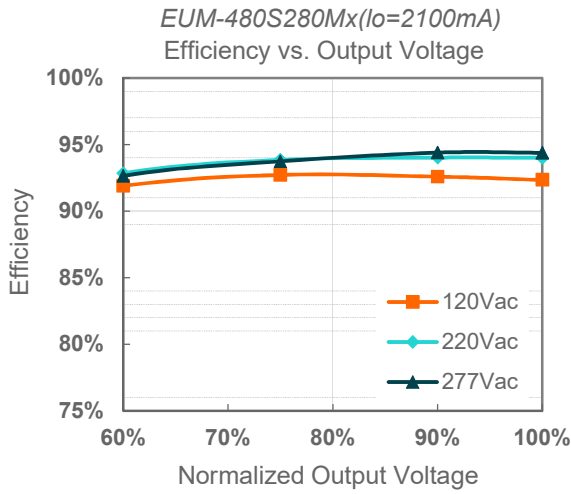

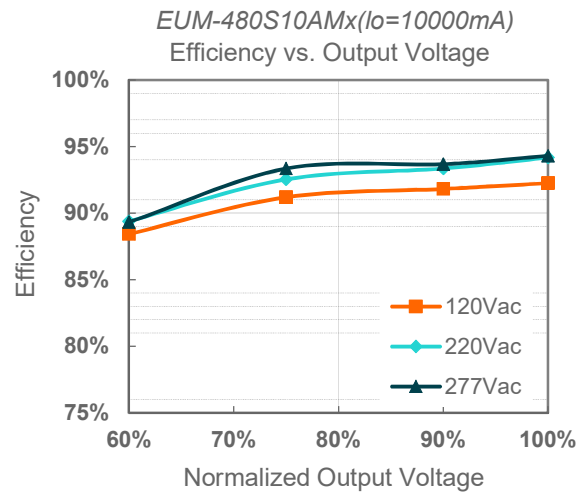
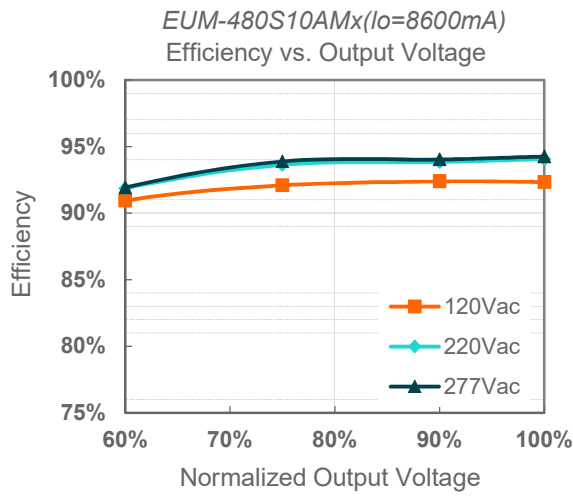

Power Factor

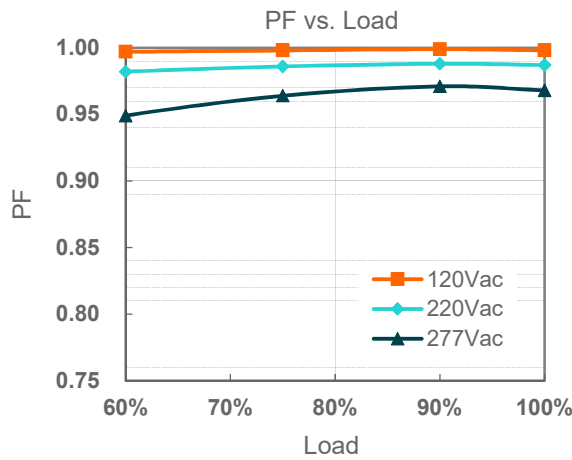

Total Harmonic Distortion

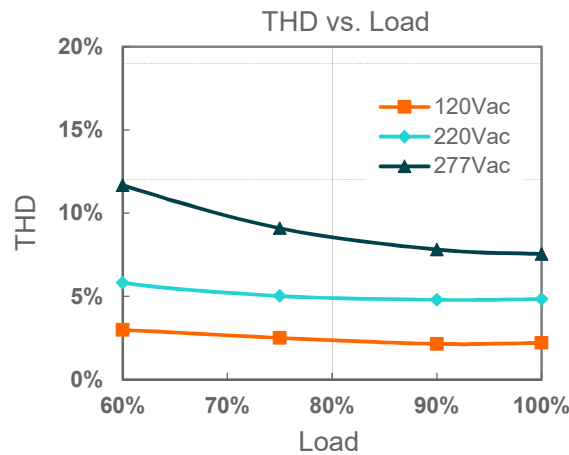

Hot-plugging Protection

This feature protects LEDs when connecting to a driver that is already powered on. This is disabled by default and can be enabled through the Inventronics Programming software.

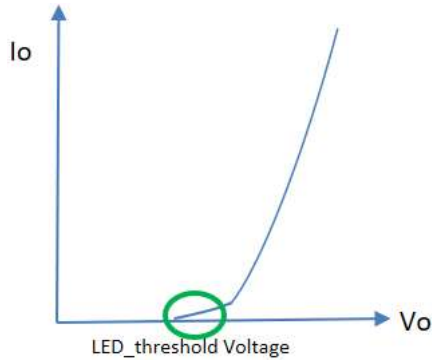

LED threshold voltage (V_{th}) is the minimum voltage required for current to flow through the LED load. After this threshold is met, the LED forward voltage (V_f) increases as the current increases.

Set V_{th} close to, but higher than the actual LED threshold voltage for optimized performance. The greater the difference between the V_{th} setting and the actual LED threshold voltage, the higher the overshoot current will be. The V_{th} setting must be lower than V_f .

Please test, program, and tune this feature for each LED load design.

Parameter		Min.	Typ.	Max.	Notes	
Hot-plugging Protection	LED Threshold Voltage Setting Range	EUM-480S140Mx	257V	-	457V	Set V_{th} close to, but higher than the actual LED threshold voltage
		EUM-480S280Mx	129V	-	228V	
		EUM-480S420Mx	86V	-	152V	
		EUM-480S560Mx	64V	-	110V	
		EUM-480S10AMx	36V	-	56V	
Setting Tolerance		-2%	-	2%		

Parallel LED Protection

This feature helps protect parallel LEDs from a high, overcurrent condition by limiting the voltage. This is disabled by default and can be enabled through the Inventronics Programming software.

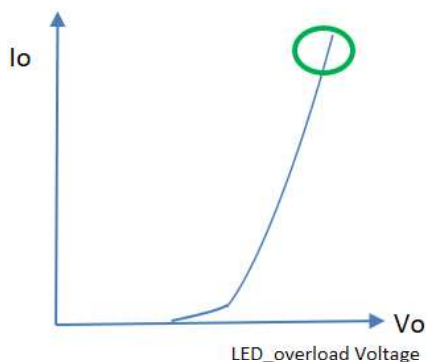

Set $V_{overload}$ close to, but higher than the maximum forward voltage for optimized performance. The greater the difference between the $V_{overload}$ setting and the maximum forward voltage, the higher the overload stress will be. The $V_{overload}$ setting must be higher than V_f .

Please test, program, and tune this feature for each LED load design.

Parallel LED Protection (Continued)

Parameter		Min.	Typ.	Max.	Notes	
Parallel LED Protection	Overload Voltage Setting Range	EUM-480S140Mx	257V	-	480V	Set V_{overload} close to, but higher than the maximum LED forward voltage
		EUM-480S280Mx	129V	-	240V	
		EUM-480S420Mx	86V	-	160V	
		EUM-480S560Mx	64V	-	115V	
		EUM-480S10AMx	36V	-	57V	
Setting Tolerance		-2%	-	2%		

Protection Functions

Parameter		Min.	Typ.	Max.	Notes
Over Temperature Protection		Decreases output current, returning to normal after over temperature is removed.			
Short Circuit Protection		Auto Recovery. No damage will occur when any output is short circuited. The output shall return to normal when the fault condition is removed.			
Over Voltage Protection		Limits output voltage at no load and in case the normal voltage limit fails.			
Input Under Voltage Protection (IUVP)	Input Protection Voltage	70 Vac	80 Vac	90 Vac	Turn off the output when the input voltage falls below protection voltage.
	Input Recovery Voltage	75 Vac	85 Vac	95 Vac	Auto Recovery. The driver will restart when the input voltage exceeds recovery voltage.
Input Over Voltage Protection (IOVP)	Input Over Voltage Protection	310 Vac	320 Vac	330 Vac	Turn off the output when the input voltage exceeds protection voltage.
	Input Over Voltage Recovery	300 Vac	310 Vac	320 Vac	Auto Recovery. The driver will restart when the input voltage falls below recovery voltage.
	Max. of Input Over Voltage			350 Vac	The driver can survive for 8 hours with a stable input voltage stress of 350Vac.

● Input Under Voltage Protection Diagram

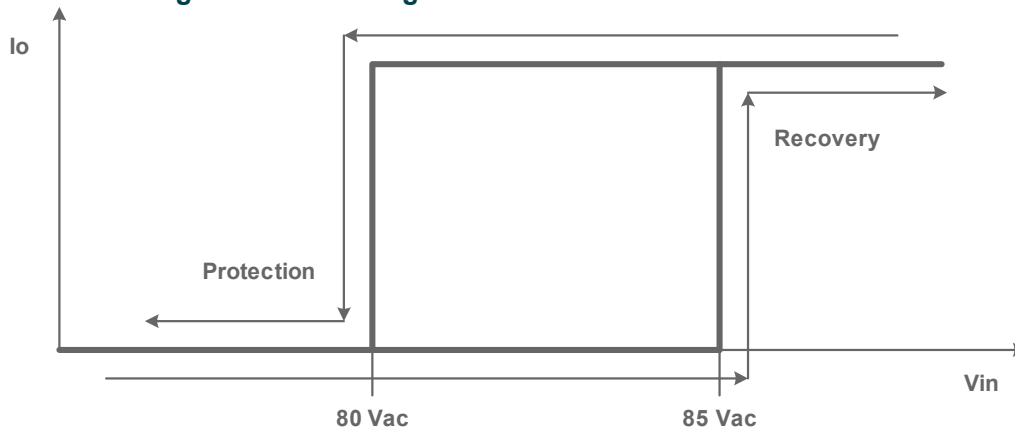

● Input Over Voltage Protection Diagram

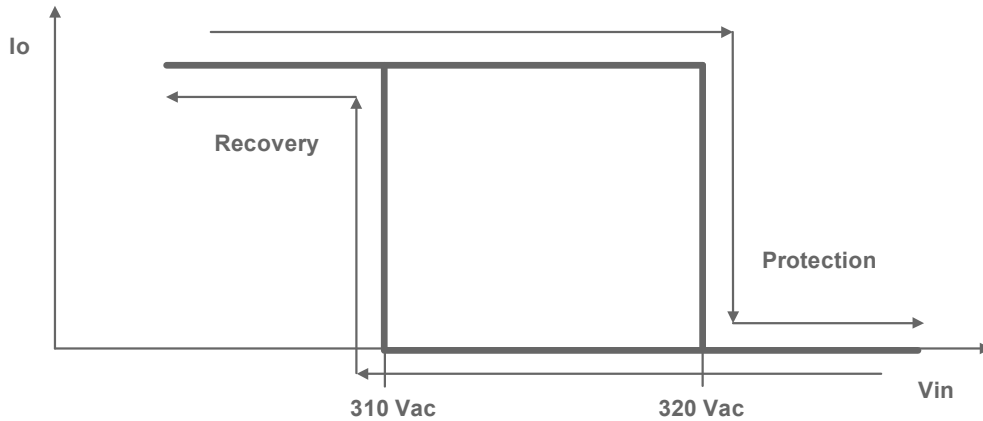

Dimming

● 0-10V Dimming

The recommended implementation of the dimming control is provided below.

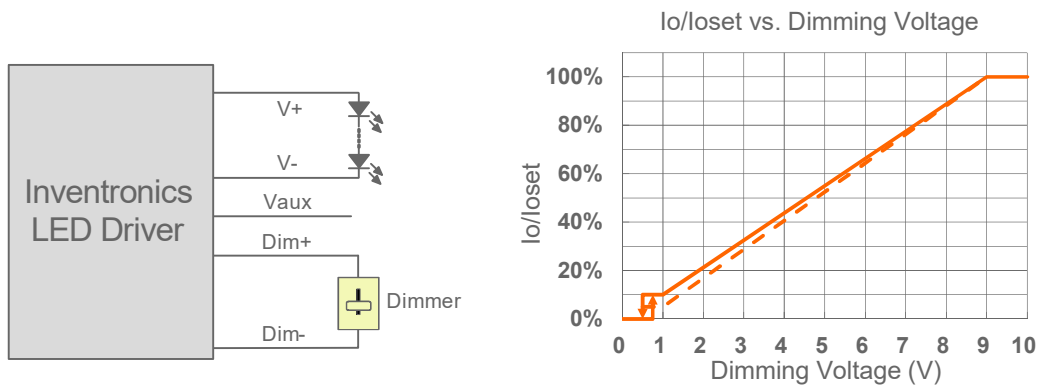

Implementation 1: Positive logic

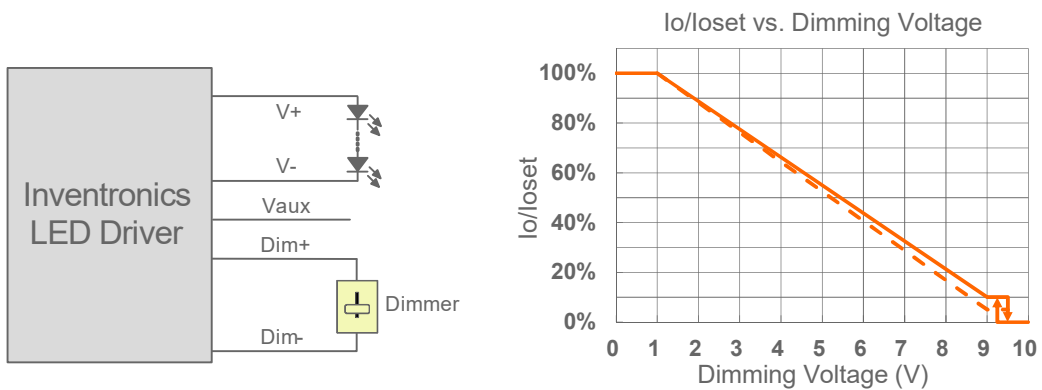

Implementation 2: Negative logic

Notes:

1. Do NOT connect $Dim-$ to the output V_- or V_+ , otherwise the driver will not work properly.
2. The dimmer can also be replaced by an active 0-10V voltage source signal or passive components like zener.
3. When 0-10V negative logic dimming mode and $Dim+$ is open, the driver will dim to off and be standby.

● PWM Dimming

The recommended implementation of the dimming control is provided below.

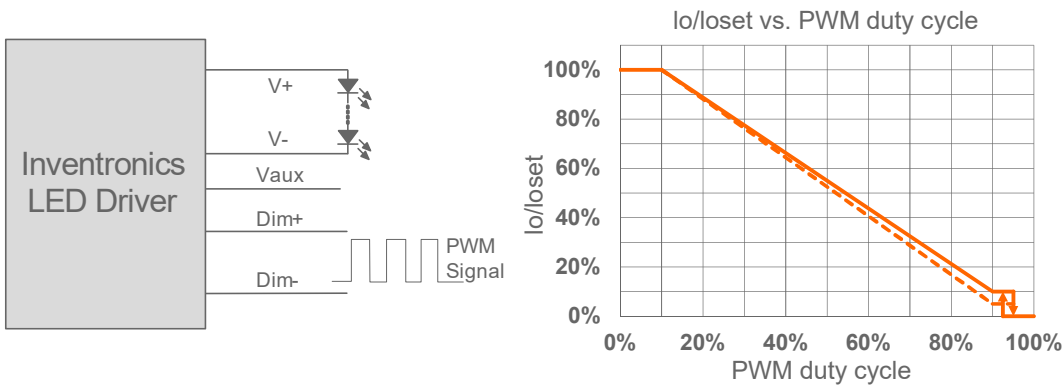
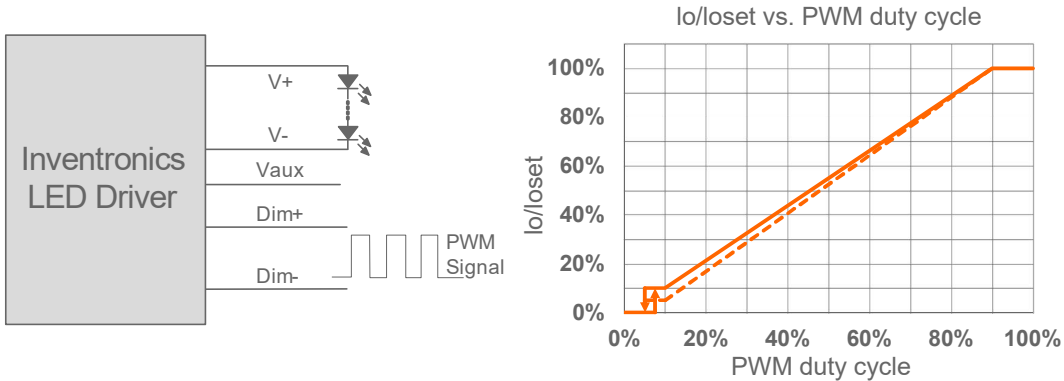

Notes:

1. Do NOT connect Dim- to the output V- or V+, otherwise the driver will not work properly.
2. When PWM negative logic dimming mode and Dim+ is open, the driver will dim to off and be standby.

● Resistor Dimming

The recommended implementation of the dimming control is provided below.

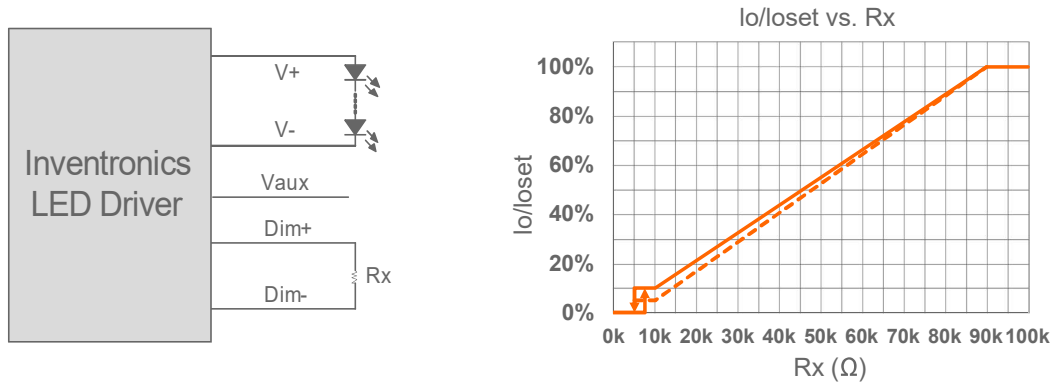

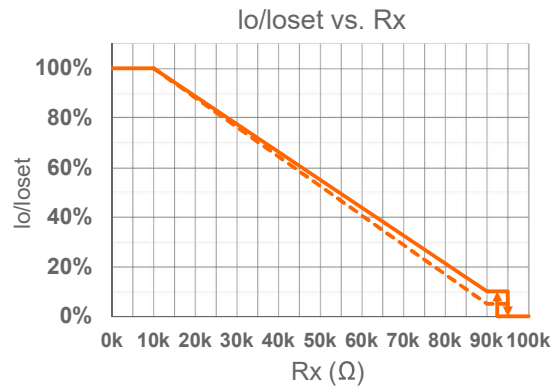
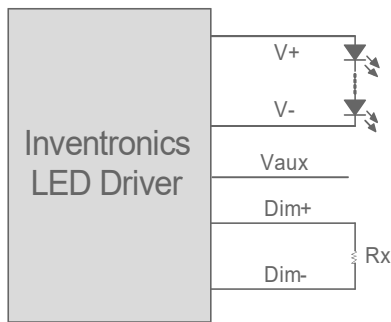

Implementation 6: Negative logic

Notes:

1. Do NOT connect Dim- to the output V- or V+, otherwise the driver will not work properly.
2. When resistor negative logic dimming mode and Dim+ is open, the driver will dim to off and be standby.

Adjustable Dimming Curve

0-10V dimming curve can be set as corresponding dimming voltage by Inventronics Multi Programmer. Take the positive logic dimming mode as an example, the recommended implementation of the dimming control is provided below.

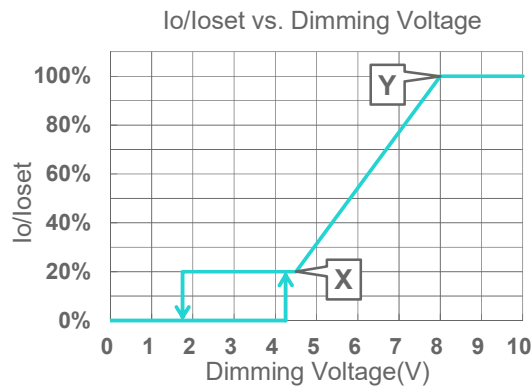
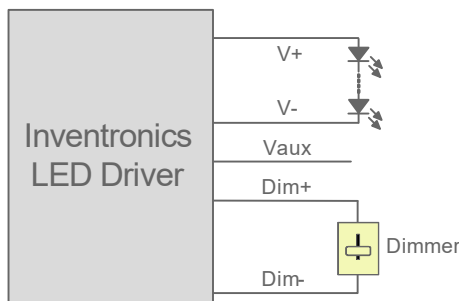

Implementation 7: Positive logic

Notes:

1. Do NOT connect Dim- to the output V- or V+, otherwise the driver will not work properly.
2. The dimmer can also be replaced by an active 0-10V voltage source signal or passive components like zener.
3. When dimming voltage X point is set to be smaller than Y point, the dimming curve is positive logic; conversely, when X point is set to be bigger than Y point, the dimming curve is negative logic.
4. For best dimming accuracy, the difference between X point and Y point is advised more than 4V.
5. Dimming off voltage adjustable.

Time Dimming

Time dimming control includes 3 kinds of modes, they are Self Adapting-Midnight, Self Adapting-Percentage and Traditional Timer.

- **Self Adapting-Midnight:** Automatically adjusts the dimming curve based on the on-time of past two days (if difference <15 minutes), assuming that the center point of the dimming curve is midnight local time.
- **Self Adapting-Percentage:** Automatically adjusts the on-time of each step by a constant percentage = (actual on-time for the past 2 days if difference <15 min) / (programmed on-time from the dimming curve).
- **Traditional Timer:** Follows the programmed timing curve after power on with no changes.

- **Output Lumen Compensation**

Output Lumen Compensation (OLC) may be used to maintain constant light output over the life of the LEDs by driving them at a reduced current when new, then gradually increasing the drive current over time to counteract LED lumen degradation.

- **Minimum Dimming Level with 5% or 10% Selectable**

The minimum dimming level can be set as 5% or 10% by Inventronics Multi Programmer, 10% is default.

- **Hold Time Adjustable**

When AC power is first applied to the LED driver, enabling a “Hold” period can allow devices powered by the Auxiliary voltage to stabilize before the driver fades up to the maximum dimming level. During this period, the driver will not respond to external dimming commands but will respond again after the hold time ends. Both the initial dimming percentage and the duration of this hold period can be adjusted by the Inventronics Multi Programmer. This function is disabled by default.

- **Fade Time Adjustable**

There is a “Fade” period after the “Hold” period. The soft-start time and dimming slope applied to all dimming transitions can be adjusted individually. It is adjusted by the Inventronics Multi Programmer. This function is disabled by default.

- **End Of Life**

End-of-Life (EOL) is providing a visual notification to a user that the LED module has reached the end of manufacturer-specified life and that the replacement is recommended. Once active, an indication is given at each power-up of the driver, which the driver indicates this through a lower light output during the first 1 minute before normal operation is continued.

- **Digital Dimming**

Inventronics Digital Dimming is a UART (Universal Asynchronous Receive Transmitter) based communication protocol. Please refer to [Inventronics Digital Dimming](#) file for details

Programming Connection Diagram

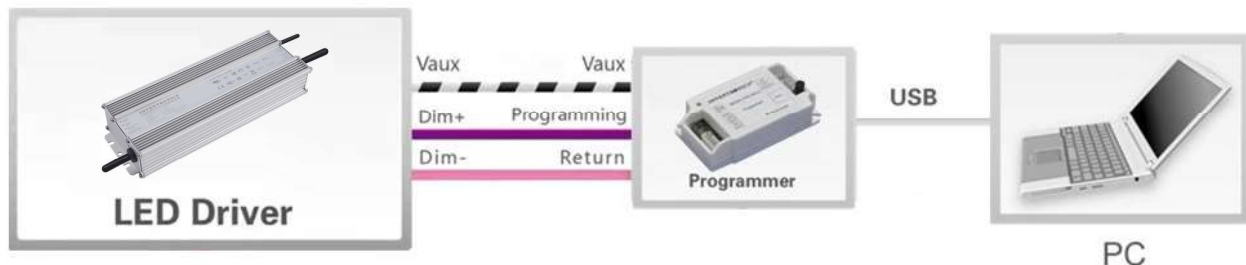

Note: The driver does not need to be powered on during the programming process.

- Please refer to [PRG-MUL2](#) (Programmer) datasheet for details.

Revision History

Change Date	Rev.	Description of Change		
		Item	From	To
2023-10-27	A	Datasheet Release	/	/
2023-11-15	B	KC/KCC	/	Added
		Safety & EMC Compliance	KC/KCC	Added
2023-12-14	C	Mechanical Outline	/	Updated