



CUSTOMER NAME \_\_\_\_\_  
 PROJECT NAME \_\_\_\_\_  
 DATE \_\_\_\_\_ TYPE \_\_\_\_\_  
 CATALOG NUMBER \_\_\_\_\_

## EWAS A Series

### LED Wall Pack

The Evolve® LED A Series Wall Pack (EWAS), offers Type II, III and IV optical patterns with lumen levels ranging from 3,000 to 17,000 lumens, and is a designed replacement for 50W to 400W HID including an optional Emergency Battery Backup. The EWAS is ideally suited for a wide range of outdoor lighting applications where energy efficiency, durability and optical performance are critical. It is an excellent choice for wall-mounted perimeter lighting, building facades, walkways, loading docks, underpass lighting, and general site illumination.

### Construction

<b>Housing:</b>	Aluminum die cast enclosure. Integral heat sink for maximum heat transfer
<b>Lens:</b>	Impact resistant tempered glass
<b>Paint:</b>	Corrosion resistant polyester powder paint, minimum 2.0 mil thickness Standard = Black, Dark Bronze, Gray & White (RAL & custom colors available)
<b>Weight:</b>	8 - 10 lbs.

### Optical System

<b>Lumens:</b>	3,000 - 17,000
<b>Distribution:</b>	Type II, III, IV
<b>CCT:</b>	3000K, 4000K, 5000K
<b>CRI:</b>	≥70

### Electrical

<b>Input Voltage:</b>	120-277V & 347-480V
<b>Input Frequency:</b>	50/60Hz
<b>Power Factor:</b>	> 90% at rated watts
<b>Total Harmonic Distortion:</b>	< 20% at rated watts

### Surge Protection

TYPICAL (120 STRIKES)	ENHANCED (40 STRIKES)	EXTREME (40 STRIKES)
6kV/3kA*	10kV/5kA*	20kV/10kA*

\*Per ANSI C136.2-2015

### Warranty

5 Year (Standard)

### Lumen Maintenance

#### Projected Lxx per IES TM-21-11 at 25°C

DISTRIBUTION	LXX(10K) @ HOURS		
	25,000 HR	50,000 HR	60,000 HR
A2, A3, A4, B2, B3, B4, C2, C3, C4, D2, D3, D4	L95	L93	L92
E2, E3, E4, F2, F3, F4, G2, G3, G4	L96	L94	L94

Note: Projected Lxx based on LM80 (≥ 10,000 hour testing). Accepted industry tolerances apply to initial luminous flux and lumen maintenance measurements.

#### Luminaire Ambient Temperature Factor

AMBIENT TEMP (°C)	INITIAL FLUX FACTOR	AMBIENT TEMP (°C)	INITIAL FLUX FACTOR
10	1.02	30	0.99
20	1.01	40	0.98
25	1.00	50	0.97

### Ratings

<b>Operating Temperature:</b>	-40°C to 40°C
<b>Vibration:</b>	3G per ANSI C136.31-2010
<b>LM-79:</b>	Testing in accordance with IESNA Standards

### Controls

<b>Dimming:</b>	Standard - 0-10V Optional - DALI (Option U)
<b>Sensors:</b>	Photo Electric Sensors (PE) available LightGrid+™ and Daintree Compatible

### Emergency Battery Backup

Provides reliable emergency operations when there is a loss to normal power, supported by Independent Secondary Battery and LED Board.

Powers luminaire for a minimum of 90 minutes @ 1,000 lumens.

Available on A\* and B\* Optical Code Packages only

Operating Temperature (for EMBB models) -20° to 40°C

3kV/1.5kA surge protection for EMBB models.

Not all product variations listed on this page are DLC qualified.  
 Visit [www.designlights.org/search](http://www.designlights.org/search) to confirm qualifications.



CUSTOMER NAME \_\_\_\_\_  
 PROJECT NAME \_\_\_\_\_  
 DATE \_\_\_\_\_ TYPE \_\_\_\_\_  
 CATALOG NUMBER \_\_\_\_\_

### Ordering Information

**EWAS 01**

**7**

**FM**

PROD. ID	GEN	VOLTAGE	OPTIC CODE	DISTRIBUTION	CRI (MIN)	CCT	DIMMING	PE FUNCTION		COLOR	OPTIONS
E = Evolve W = Wallpack AS = A-Series	01	0 = 120-277V H = 347-480V 1 = 120V 2 = 208V 3 = 240V 4 = 277V D = 347V 5 = 480V	Ax = 3000 lm Bx = 5000 lm Cx = 7500 lm Dx = 10000 lm Ex = 12200 lm Fx = 14400 lm Gx = 17000 lm	AF = Asymmetric Forward AN = Asymmetric Narrow AW = Asymmetric Wide	7 = 70 CRI	30 = 3000K <sup>10</sup> 40 = 4000K 50 = 5000K	D = External Dimming leads N = No external Dimming Leads	1 = None 3 = Button PE <sup>1,2</sup> A = ANSI C136.41 7-Pin Receptacle D = ANSI C136.417-Pin Receptacle with Shorting Cap <sup>12</sup> E = ANSI C136.41 7-Pin with Non-Dimming PE Control <sup>11</sup>	FM = Surface Mount/Feed Through	BLCK = Black DKBZ = Dark Bronze GRAY = Gray WHITE = White	EMBB = Emergency Battery Backup <sup>3,8,12</sup> R = Enhanced Surge Protection (10kV/5kA) T = Extreme Surge Protection (20kV/10kA) H = Motion Sensor <sup>4,5</sup> H2 = Daintree Motion Sensor <sup>6,7,8</sup> Y = Coastal Finish <sup>9</sup> XXX = Special Options

<sup>1</sup> Button PE not available with motion sensor option.

<sup>2</sup> Not available with voltage options 0, H, or 5.

<sup>3</sup> Available with A and B Optical Codes Only

<sup>4</sup> H Motion Sensor Bottom mount available with A, B, C, D, & E Optical Codes Only

<sup>5</sup> H Motion Sensor Side Mount available with F & G Optical Codes Only

<sup>6</sup> H2 Daintree Motion Sensor Bottom mount available with A, B, C, D, & E Optical Codes Only

<sup>7</sup> H2 Not Available with F & G Optical Codes

<sup>8</sup> Not available in 347V, 480V or 347-480V

<sup>9</sup> Recommended for installations within 750 feet from coast. Lead time varies, check with factory.

<sup>10</sup> Select 3000K CCT for IDA approved fixtures.

<sup>11</sup> PE Control only available for 120-277V, 347V or 480V Discrete Voltage.

<sup>12</sup> EMBB is not available with surge protection, fuses, sensors, or ANSI C136.41 7-pin Receptacle

CUSTOMER NAME \_\_\_\_\_

PROJECT NAME \_\_\_\_\_

DATE \_\_\_\_\_ TYPE \_\_\_\_\_

CATALOG NUMBER \_\_\_\_\_

TYPE	OPTIC CODE	DISTRIBUTION	TYPICAL INITIAL LUMENS		TYPICAL SYSTEM WATTAGE		BUG RATINGS	
			3000K	4000K & 5000K	120-277V	347-480V	3000K	4000K & 5000K
							B-U-G	B-U-G
Type IV	A4	Asymmetric Forward (AF)	2900	3000	21	23	B1-U0-G1	B1-U0-G1
	B4		4900	5000	36	38	B1-U0-G1	B1-U0-G1
	C4		7300	7500	56		B1-U0-G2	B1-U0-G2
	D4		9800	10000	77		B2-U0-G2	B2-U0-G2
	E4		11500	12200	89		B2-U0-G2	B2-U0-G2
	F4		13600	14400	109		B2-U0-G2	B2-U0-G2
	G4		16100	17000	130		B3-U0-G3	B3-U0-G3
Type III	A3	Asymmetric Wide (AW)	2900	3000	21	23	B1-U0-G1	B1-U0-G1
	B3		4900	5100	36	38	B1-U0-G1	B1-U0-G1
	C3		7400	7600	56		B2-U0-G1	B2-U0-G1
	D3		9900	10200	77		B2-U0-G2	B2-U0-G2
	E3		11700	12400	89		B2-U0-G2	B2-U0-G2
	F3		13900	14700	109		B2-U0-G2	B2-U0-G2
	G3		16400	17300	130		B2-U0-G2	B3-U0-G2
Type II	A2	Asymmetric Narrow/ Auto (AN)	2900	3000	21	23	B1-U0-G1	B1-U0-G1
	B2		4900	5000	36	38	B1-U0-G1	B1-U0-G1
	C2		7300	7500	56		B2-U0-G1	B2-U0-G2
	D2		9800	10100	77		B2-U0-G2	B2-U0-G2
	E2		11600	12300	89		B2-U0-G2	B2-U0-G2
	F2		13700	14500	109		B3-U0-G3	B3-U0-G3
	G2		16200	17100	130		B3-U0-G3	B3-U0-G3

For additional information on EWAS IES files, please refer to LED.com

**EWAS**  
ASYMMETRIC NARROW  
(D2AN750)

10,100 Lumens  
5000K  
EWAS01\_D2AN750\_IES

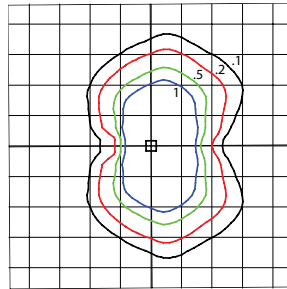

- Mounting Height at 15'
- Initial Footcandle at Grade

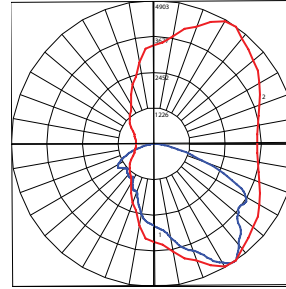

- Vertical plane through horizontal angle of Max. Cd at 55°
- Horizontal cone through vertical angle of Max. Cd at 34°

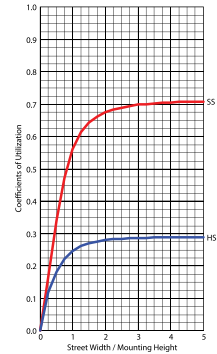

**EWAS**  
ASYMMETRIC WIDE  
(D3AW750)

10,200 Lumens  
5000K  
EWAS01\_D3AW750\_IES

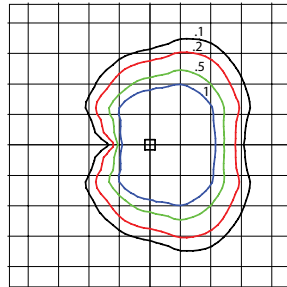

- Mounting Height at 15'
- Initial Footcandle at Grade

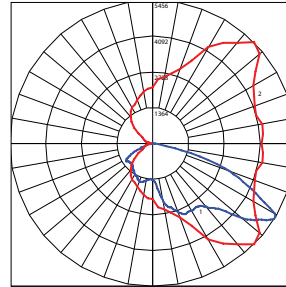

- Vertical plane through horizontal angle of Max. Cd at 45°
- Horizontal cone through vertical angle of Max. Cd at 59°

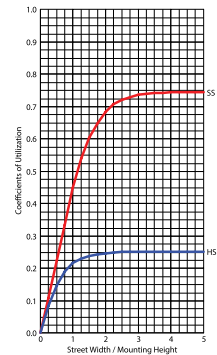

**EWAS**  
ASYMMETRIC FORWARD  
(D4AF750)

10,000 Lumens  
5000K  
EWAS01\_D4AF750\_IES

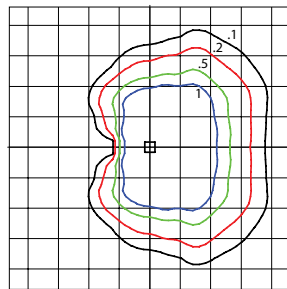

- Mounting Height at 15'
- Initial Footcandle at Grade

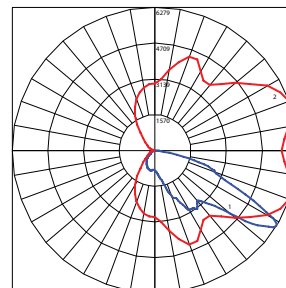

- Vertical plane through horizontal angle of Max. Cd at 20°
- Horizontal cone through vertical angle of Max. Cd at 58°

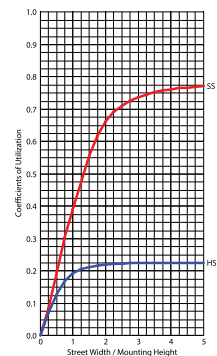

**EWAS**  
ASYMMETRIC NARROW  
(G2AN750)

17,100 Lumens  
5000K  
EWAS01\_G2AN750\_IES

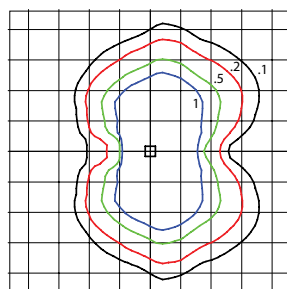

- Mounting Height at 15'
- Initial Footcandle at Grade

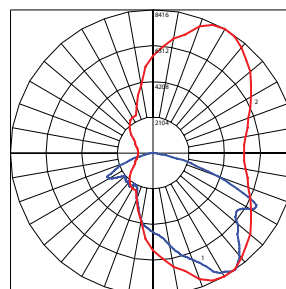

- Vertical plane through horizontal angle of Max. Cd at 60°
- Horizontal cone through vertical angle of Max. Cd at 35°

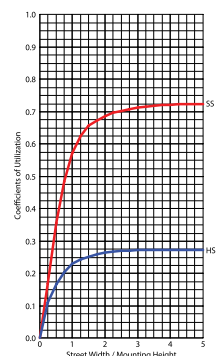

**EWAS**  
ASYMMETRIC WIDE  
(G3AW750)

17,300 Lumens  
5000K  
EWAS01\_G3AW750\_IES

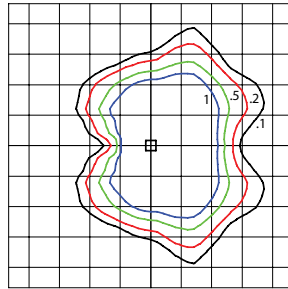

- Mounting Height at 15'
- Initial Footcandle at Grade

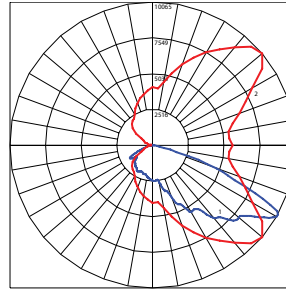

- Vertical plane through horizontal angle of Max. Cd at 40°
- Horizontal cone through vertical angle of Max. Cd at 61°

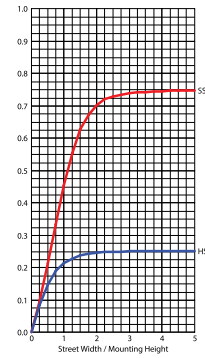

**EWAS**  
ASYMMETRIC FORWARD  
(G4AF750)

17,000 Lumens  
5000K  
EWAS01\_G4AF750\_IES

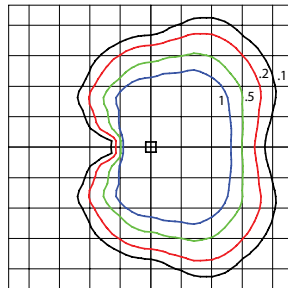

- Mounting Height at 15'
- Initial Footcandle at Grade

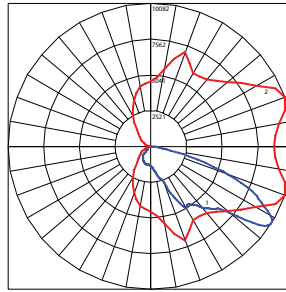

- Vertical plane through horizontal angle of Max. Cd at 20°
- Horizontal cone through vertical angle of Max. Cd at 57°

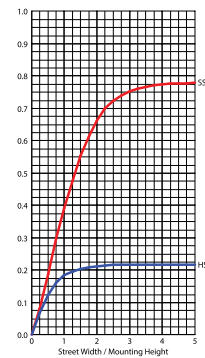

**EWAS**  
(With Emergency Battery  
Backup in Operation)

1,000 Lumens  
3000K, 4000K, 5000K  
EWAS01\_With Emergency  
Battery Backup On\_IES

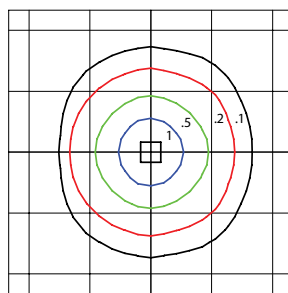

- Mounting Height at 15'
- Initial Footcandle at Grade

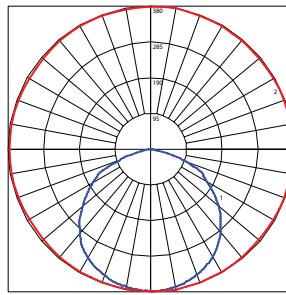

- Vertical plane through horizontal angle of Max. Cd at 80°
- Horizontal cone through vertical angle of Max. Cd at 1°

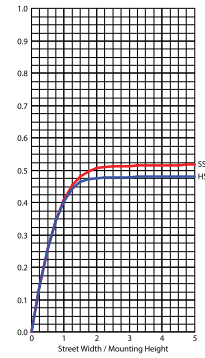

CUSTOMER NAME \_\_\_\_\_  
 PROJECT NAME \_\_\_\_\_  
 DATE \_\_\_\_\_ TYPE \_\_\_\_\_  
 CATALOG NUMBER \_\_\_\_\_

### H - Motion Sensing Option

<b>Recommended Mounting Height:</b>	8-25ft
<b>Coverage Radius:</b>	25-30 ft
<b>Lateral Coverage</b>	Provides 180° coverage (180° blocked by wall)
<b>Default Settings</b>	
<b>Output:</b>	Occupied - 100% Unoccupied - 50%
<b>PE Sensor:</b>	Enabled
<b>Ramp/Fade:</b>	10% dimming after 5 minutes with no occupancy
<b>Adds:</b>	Adds < 1W to fixture power rating
<b>Field:</b>	Field programmable using FSIR-100 hand held programmer

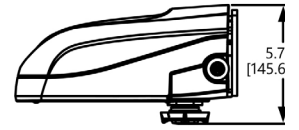
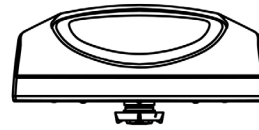

**H Option - Wattstopper Motion Sensor**  
 Bottom mount available with A, B, C, D, & E Optical Codes Only

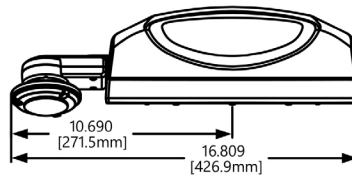

**H Option - Wattstopper® Motion Sensor**  
 Side mount available with F & G Optical Codes Only

### H2 - Daintree Enabled Motion Sensing Option

<b>Recommended Mounting Height:</b>	8-25ft
<b>Coverage Radius:</b>	15-30 ft
<b>Lateral Coverage</b>	Provides 180° coverage (180° blocked by wall)
<b>Default Settings:</b>	
<b>Output:</b>	Occupied - 100% Unoccupied - 50%
<b>PE Sensor:</b>	Enabled
<b>Ramp/Fade:</b>	5 Minutes/5 Minutes
	Adds < 1W to fixture power rating
	Requires Daintree Enterprise and wide area control (WAC)

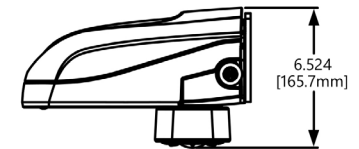
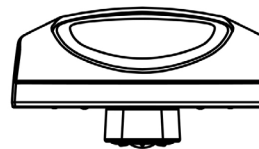

**H2 Option - Daintree Motion Sensor**  
 Bottom mount available with A, B, C, D, & E Optical Codes Only

### SENSOR PATTERN

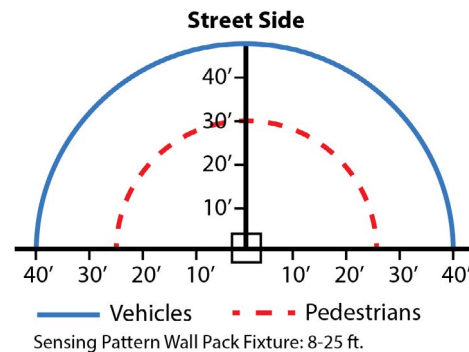

CUSTOMER NAME \_\_\_\_\_  
 PROJECT NAME \_\_\_\_\_  
 DATE \_\_\_\_\_ TYPE \_\_\_\_\_  
 CATALOG NUMBER \_\_\_\_\_

**TOP VIEW**

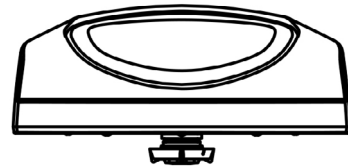
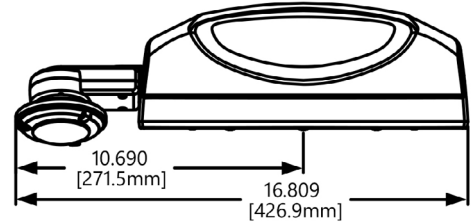
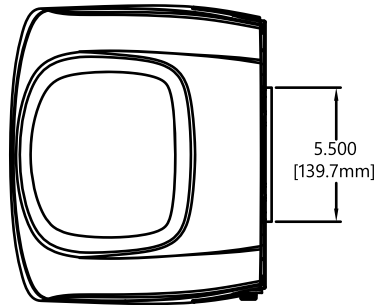

**FRONT VIEW**

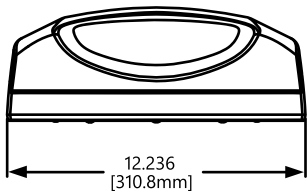

**SIDE VIEW**

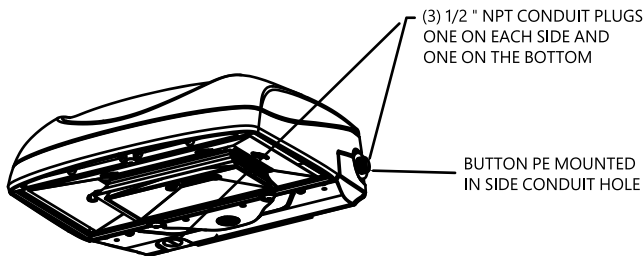
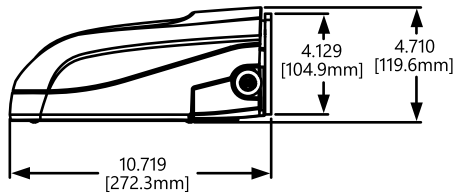

**7-PIN RECEPTACLE/ TOP OF LUMINAIRE**

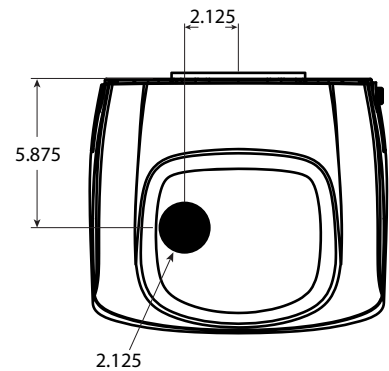

### Mounting

Flush Mount: Mounts directly to customer supplied junction box

Surface Mount: Mounts to walls via separate mounting holes.