

Evolve® LED Wall Pack

L Series (EWLS)

Project Name _____
 Date _____ Type _____
 Notes _____

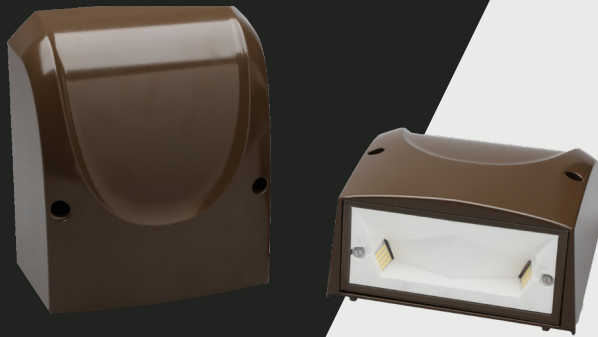

The Evolve® LED L Series Wall Pack (EWLS), The Evolve LED L-Series Wall Pack, EWLS, is a designed replacement for 50W to 250W HID, while offering significant energy savings in a long-life LED wall pack. Two-screw housing design enables a fast and simplified installation. The low-watt Egress package is designed to meet recommended illuminance requirements for egress applications such as side and rear exit doors in commercial buildings. Available with Emergency Battery Backup option.



CONSTRUCTION

Housing:	Aluminum die cast enclosure. Integral heat sink for maximum heat transfer
Lens:	Impact resistant tempered glass
Paint:	Corrosion resistant polyester powder paint, minimum 2.0 mil thickness Color: Black, Dark Bronze, Gray & White (RAL & custom colors available)
Weight:	8.5lbs (4 kg)

OPTICAL SYSTEM

Lumens:	1,700 to 7,000
Distribution:	Asymmetric Forward
Efficacy:	117- 148 LPW
CCT:	2700, 3000K, 4000K, 5000K
CRI:	≥70

ELECTRICAL

Input Voltage:	120-277V & 347V
Input Frequency:	50/60Hz
Power Factor:	> 90% at rated watts
Total Harmonic Distortion:	≤ 20% at rated watts

SURGE PROTECTION*

STANDARD	EMBB
10kV/5kA	3kV/1.5kA

*Per ANSI C136.2-2015

EMERGENCY BATTERY BACKUP

Provides reliable emergency operations when there is a loss to normal power, supported by Independent Secondary Battery.

- Hold-Up Time: 90 minutes @ 1,400 lumens.
- Meet egress light level and uniformity requirements
- Not available in 347V
- Operating Temperature (for EMBB models) 0° to 40°C
- 3kV/1.5kA surge protection for EMBB models.

LUMEN MAINTENANCE

Projected Lxx per IES TM-21-11 at 25°C

Lumen Codes	Distribution	LXX(10K) @ Hours		
		25,000 HR	50,000 HR	60,000 HR
17, 25 & 40	AF	L99	L99	L99
70	AF	L94	L87	L85

Note: Projected Lxx based on LM80 (≥ 10,000 hour testing). Accepted industry tolerances apply to initial luminous flux and lumen maintenance measurements.

LUMINAIRE AMBIENT TEMPERATURE FACTOR

Ambient Temp (°C)	Initial Flux Factor	Ambient Temp (°C)	Initial Flux Factor
10	1.02	30	0.99
20	1.01	40	0.98
25	1.00	50	0.97

RATINGS

Operating Temperature:	-40°C to 50°C
Vibration:	3G per ANSI C136.31-2010 1.5G Voltage Code D (347V)
LM-79:	Testing in accordance with IESNA Standards

CONTROLS

Dimming:	Standard - 0-10V
Sensors:	Photo Electric Sensors (PE) available Motion Sensor

WARRANTY

5 Year (Standard)



Evolve® LED Wall Pack

L Series (EWLS)

Catalog Logic & Spec Tables

Project Name _____

Date _____ Type _____

Notes _____

EWLS 02

7

PROD. ID	GEN	VOLTAGE	OPTIC CODE	DISTRIBUTION	CRI (min)	CCT	CONTROLS	PE FUNCTION	MOUNTING	COLOR	OPTIONS
E = Evolve	02	0 = 120-277	17 = 1,700 lms ²	AF = Asymmetric Forward	7 = 70	27 = 2700K ³	N = No External Dimming Leads	1 = None	CB = Conduit Box Mount ⁴	BLCK = Black	EMBB = Emergency Battery Backup ^{5,6}
W = Wallpack		1 = 120 ¹	25 = 2,500 lms			30 = 3000K ³	D = External Dimming Leads ⁵	3 = Button PE ⁷	FM = Flush Mount	DKBZ = Dark Bronze	H = Motion Sensor (Wattstopper) ^{8,9}
LS = L-Series		2 = 208 ¹	40 = 4,000 lms			40 = 4000K				GRAY = Gray	J = cUL/Canada
		3 = 240 ¹	70 = 7,000 lms			50 = 5000K				WHITE = White	W = Non-Graphical White Box
		4 = 277 ¹									XXX = Special Options
		8 = 120-240									
		D = 347 ¹									

¹ Specify single voltage if Button PE option is selected

² Optic code 17 - Not offered in 120-277V, use 120-240V

³ Select 2700K or 3000K CCT for IDA approved units

⁴ Must be selected when ordering with Button PE, Motion Sensor, 347V or Emergency Battery Backup

⁵ Not available with motion sensor

⁶ Not available in 347V

⁷ Button PE not available with EMBB. Button PE not available with H Motion Sensor. Motion sensor includes dusk-to-dawn control as well as motion control.

⁸ WS FSIR-100 (Sku# 197634) needed for programming sensor.

⁹ Must select Controls "N" with Motion Sensor "H"

OPTIC CODE	DISTRIBUTION	TYPICAL INITIAL LUMENS			TYPICAL SYSTEM WATTAGE		BUG RATINGS 2700K-5000K B-U-G
		2700K	3000K	4000K/5000K	120-277V	347V	
17	AF	1400	1600	1700	12	14	B1-U0-G0
25		2200	2400	2500	17	19	B1-U0-G1
40		3500	3800	4000	27	29	B1-U0-G1
70		6100	6700	7000	52	54	B2-U0-G1
EMBB	-	1300	1400	1400	-	-	B1-U0-G0

For additional information on EWLS IES files, please click the following link:

[EWLS IES Files](#)

Evolve[®] LED Wall Pack

L Series (EWLS)

Photometric Plots

Project Name _____

Date _____ Type _____

Notes _____

70AF

ASYMMETRIC FORWARD

7000 LUMEN

EWLS02_70AF750__-120-277V.ies

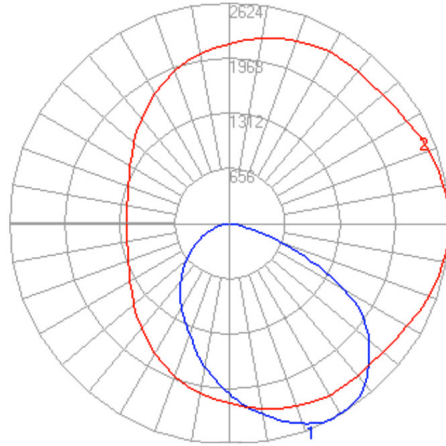

- Vertical plane through horizontal angle of Max. Cd at 0°
- Horizontal cone through vertical angle of Max. Cd at 27°

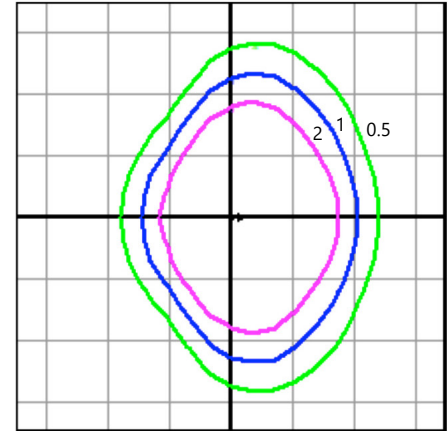

- Mounting Height at 10'
- Initial Footcandle at Grade
- Light Level: 0.5fc, 1fc, 2fc

EMBB Mode

ASYMMETRIC FORWARD

1400 LUMEN

EWLS02_EMBB__ies

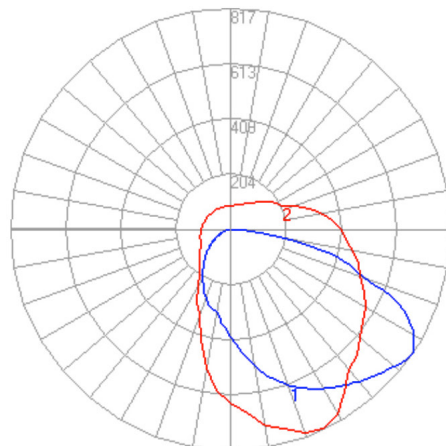

- Vertical plane through horizontal angle of Max. Cd at 295°
- Horizontal cone through vertical angle of Max. Cd at 55°

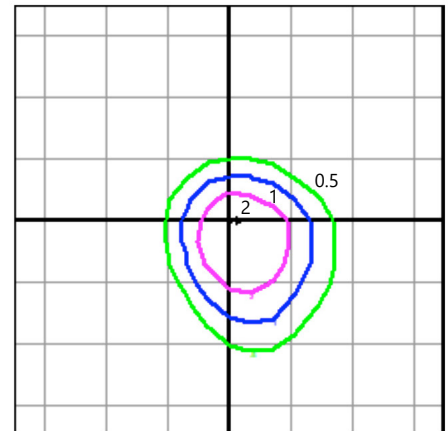

- Mounting Height at 10'
- Initial Footcandle at Grade
- Light Level: 0.5fc, 1fc, 2fc

Evolve® LED Wall Pack

L Series (EWLS)

Motion Sensing

Project Name _____

Date _____ Type _____

Notes _____

H MOTION SENSING OPTION

- Intended for 8-25ft mounting heights
- Provides coverage area radius for walking motion of 25-30 ft
- Provides 180° degree coverage (180° degree blocked by wall)
- Integrated Photoelectric control

Default Settings:

- Output: Occupied - 100%/Unoccupied - 50%
- 10% dimming after 5 minutes with no occupancy
- Adds < 1W to fixture power rating
- Field programmable using FSIR-100 hand held programmer
- SKU # 197634 (WS FSIR-100)

SENSING PATTERN:

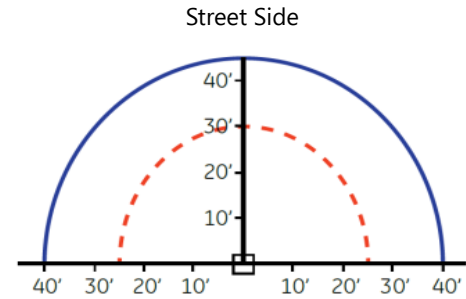

- Vehicles
- - - Pedestrians

Sensing Pattern Wall Pack Fixture: 8-25 ft.

FLUSH MOUNT

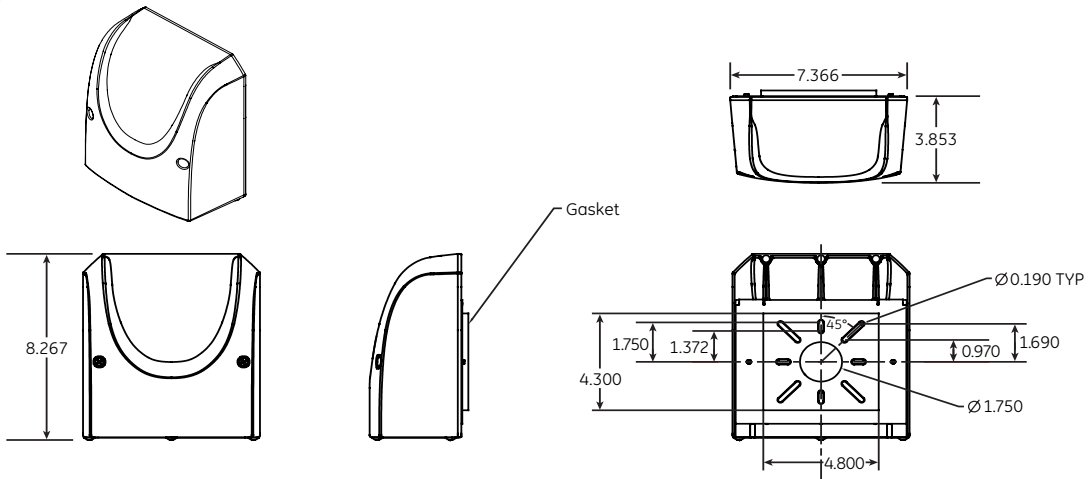

CONDUIT BOX MOUNT

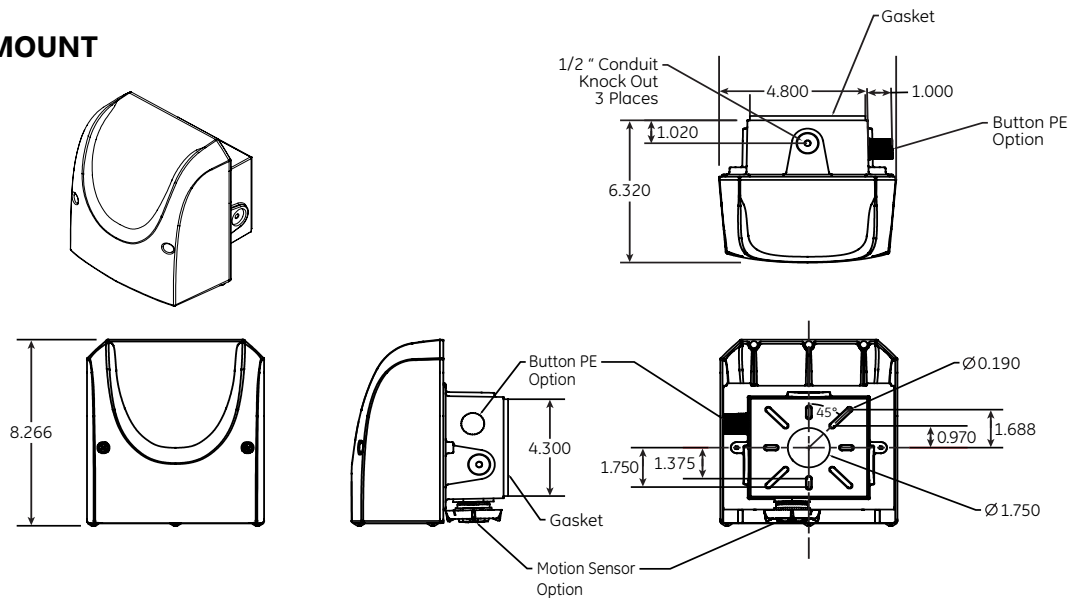

MOUNTING

- Mounts to standard 3-1/2" to 4" round and octagonal, 4" square, single gang and masonry junction boxes.
- Flush Mount: Mounts directly to customer supplied junction box
- Conduit Box Mount: Mounts to walls via separate mounting box with conduit knockouts.

ACCESSORIES

SAP Number	SKU Description	Description	Finish
93098508	EWLSAE1BLCK	10" x 12" Beauty Plate	BLACK
93098507	EWLSAE1DKBZ	10" x 12" Beauty Plate	DARK BRONZE
93098509	EWLSAE2BLCK	12" x 16" Beauty Plate	BLACK
93078134	EWLSAE2DKBZ	12" x 16" Beauty Plate	DARK BRONZE
93098506	EWLSAE2GRAY	12" x 16" Beauty Plate	GRAY
93082336	EWLSAE2WHT	12" x 16" Beauty Plate	WHITE
93117503	EWLSAE3BLCK	12" x 20" Beauty Plate	BLACK
93082337	EWLSAE3WHT	12" x 20" Beauty Plate	WHITE
93060351	EWLSAD	Diffuser	

ACCESSORIES: ESCUTCHEON PLATES

Cover the unsightly debris marks on your building facade with color matched wall pack beauty plates. Mounting hole patterns and dimensions are compatible with typical building surface fastening methods.

