



FHUPS1-UNV-12L-SD

IP20



Emergency Power Supply

- ☀️ Emergency Micro Inverter with sine wave output
Can support fixtures up to 100W with 0-10V Dimming, 18W is Triac Dimming
- ⚠️ Universal AC Input Voltage: 100-277VAC
- ⚠️ Auto Select Output Voltage: 120/220/260VAC

☀️ Output Power: 12W Max Programmable

EBD Emergency Battery Disengage
 📶 Remote Up to 150ft away with 18ga Wire
 IP20

General Specifications

Input Voltage / Frequency	100-277VAC , 50/60Hz
Input Current	0.12A Max
Input Power	7W Max
AC Load Input Power	100W Max. when using 0-10V / 18W Max. when using Triac Dimming 12W Max. when 0-10V / Triac Dimming is not used
Standby power	Meet CEC
Driver Type	Limit Max Power
Output Power	12W Max.(30VA Max.)
Output Voltage Range	120/220/260VAC,60Hz.
Load Power Factor Range	0.4-1(Leading/Lagging)
Number of Output Channels	1 Channel
RFI/EMI	FCC Part 15A Non-Consumer
Output Type	None Isolated
Battery Type	Lithium-ion Battery
Battery Capacity Available	5000mAh
Battery Recharge Time	24Hours
Battery Discharge Time	90 Minutes Min.
Test Switch Wire Length	23" (584.2mm)
Test Switch Remote Mounting Distance	65.6' (20m) Max.
Optional Wet Location Test Switch	FHS-TSTWL-BC
Accessories	Wall Plate (FHSWLPWH)
Input Surge Protection	3KV/6KV Ring wave
Protections	Under Voltage Protection Overload Protection Short Circuit Protection
Rated Ambient(ta)	US:0°C To 50°C (32°F To 122°F), Canada: 0°C To 45°C (32°F To 113°F)
Tc	60°C(140°F)
Sound Rating	A
Battery Type	Lithium-Ion battery
Battery Voltage	11.1V
Battery Capacity	5000mAh
Battery Rating	55.5Wh
Battery Recharge Time	24 Hours
Battery Discharge Time	Min 1.5 Hours
Service Life	50,000 hours
Warranty	5 years
Compliance standards	UL924, CSA C22.2 NO.141, CSA C22.2 No.223, cUL, UL1310, CEC Title 20
Class 2 circuit	DIM(+/-), 0-10V Dimming out, DIP switch, Test switch



FHUPS1-UNV-12L-SD

IP20

RoHS COMPLIANT



UL US LISTED E313578 EMER. POWER EQ.

Mechanical Diagram

Overall Dimensions	
Length	12.764" [324.2mm]
Width	2.657" [67.5mm]
Height	1.488" [37.8mm]

inch
[mm]

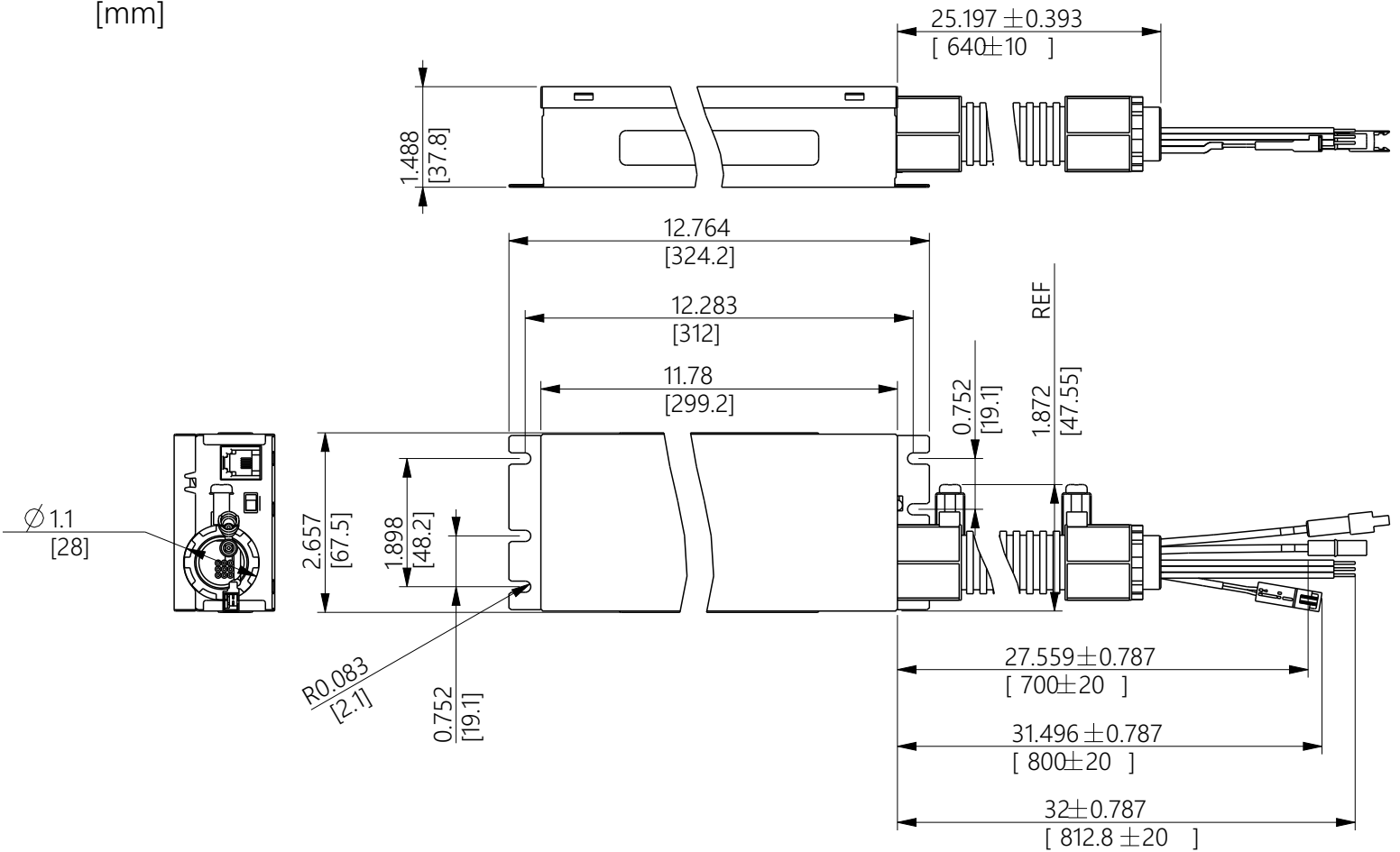

FHUPS1-UNV-12L-SD



IP20

RoHS COMPLIANT



UL US LISTED E313578 EMER. POWER EQ.

Accessories

Test switch wire

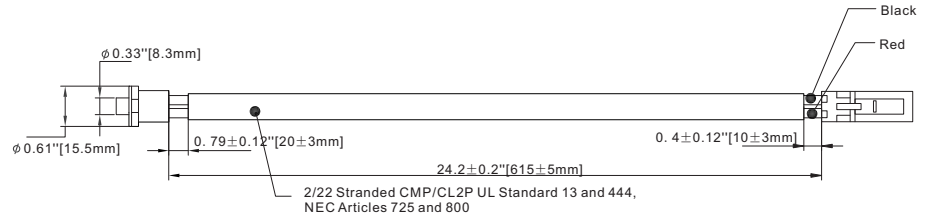

Optional Accessories

Bi-Color Wet Location Test Switch: FHS-TSTWL-BC

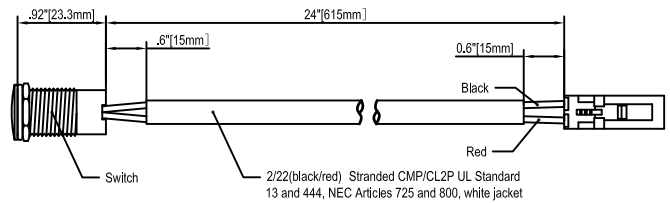

Overall Switch Dimension

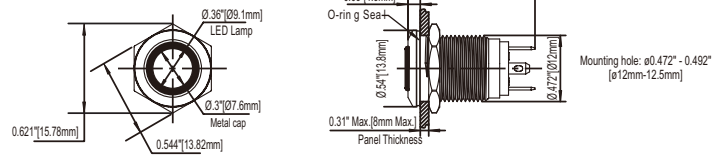

Test Switch Extension: FHS-EXT-48-TST

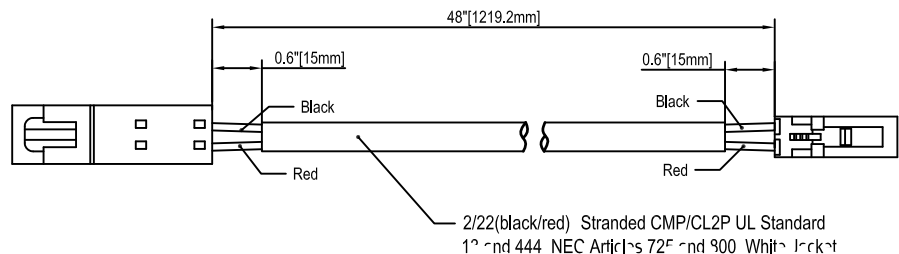



FHUPS1-UNV-12L-SD



IP20

RoHS COMPLIANT



UL US LISTED E313578 EMER. POWER EQ.

Optional Accessories

White Wet Location Test Switch: FHS-TSTWL-BC-W

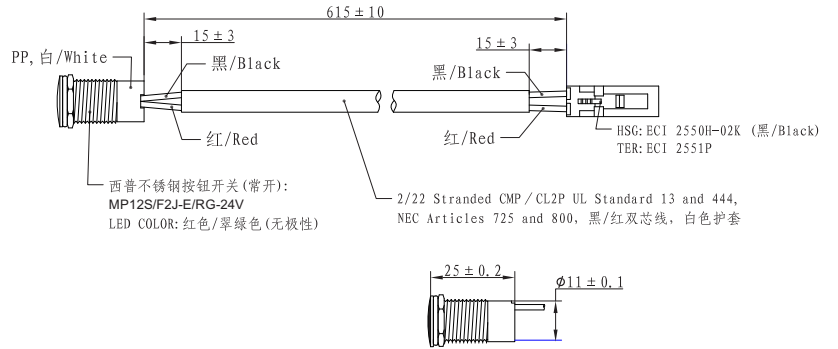

Optional Accessories

Wall Plate: FHSWLPWH



Wall plate and screw color: white with black lettering

Wall Plate: FHSWLPPWH(Pure White Wall Plate)

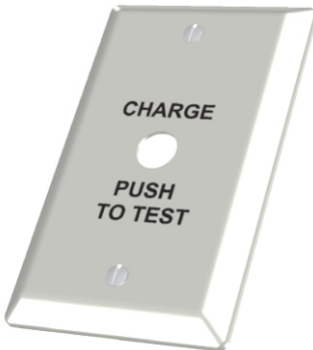

Wall plate and screw color: Pure white with black lettering

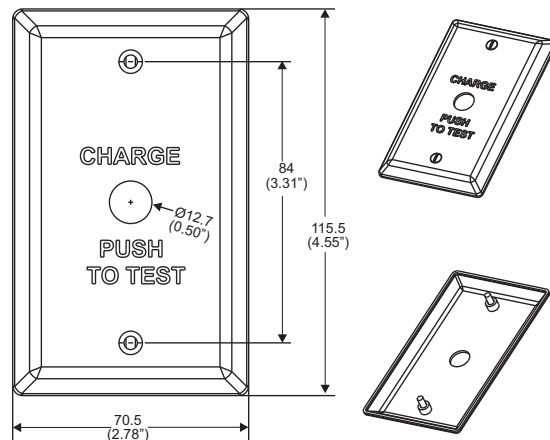

1. "Charge push to Test" plate
2. (2) 6-32 x 1/2" LG mounting screws



IP20

RoHS COMPLIANT



UL US LISTED E313578 EMER. POWER EQ.

Wiring Diagram 1

For Luminaire(s) with an output power less than 12W (30VA) and Non 0-10 dimming function.

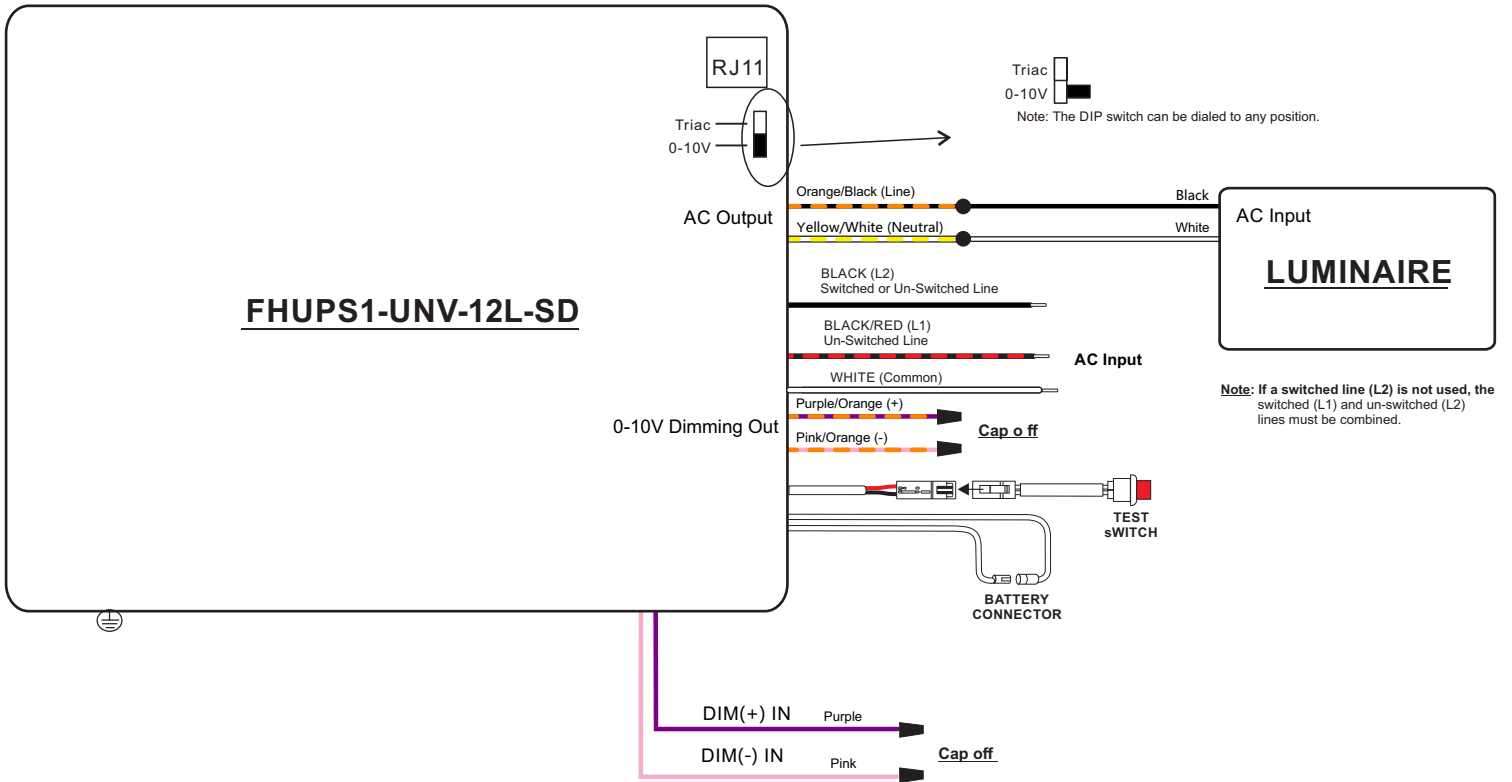

Note: Pink or Gray dimming wire provided. use interchangeably.

Note: Pink/Orange or Gray/Orange dimming wire provided. use interchangeably.



IP20

RoHS COMPLIANT



UL US LISTED E313578 EMER. POWER EQ.

Wiring Diagram 2

For Luminaire(s) with an output power less than 100W (125VA) and have 0-10 dimming function.

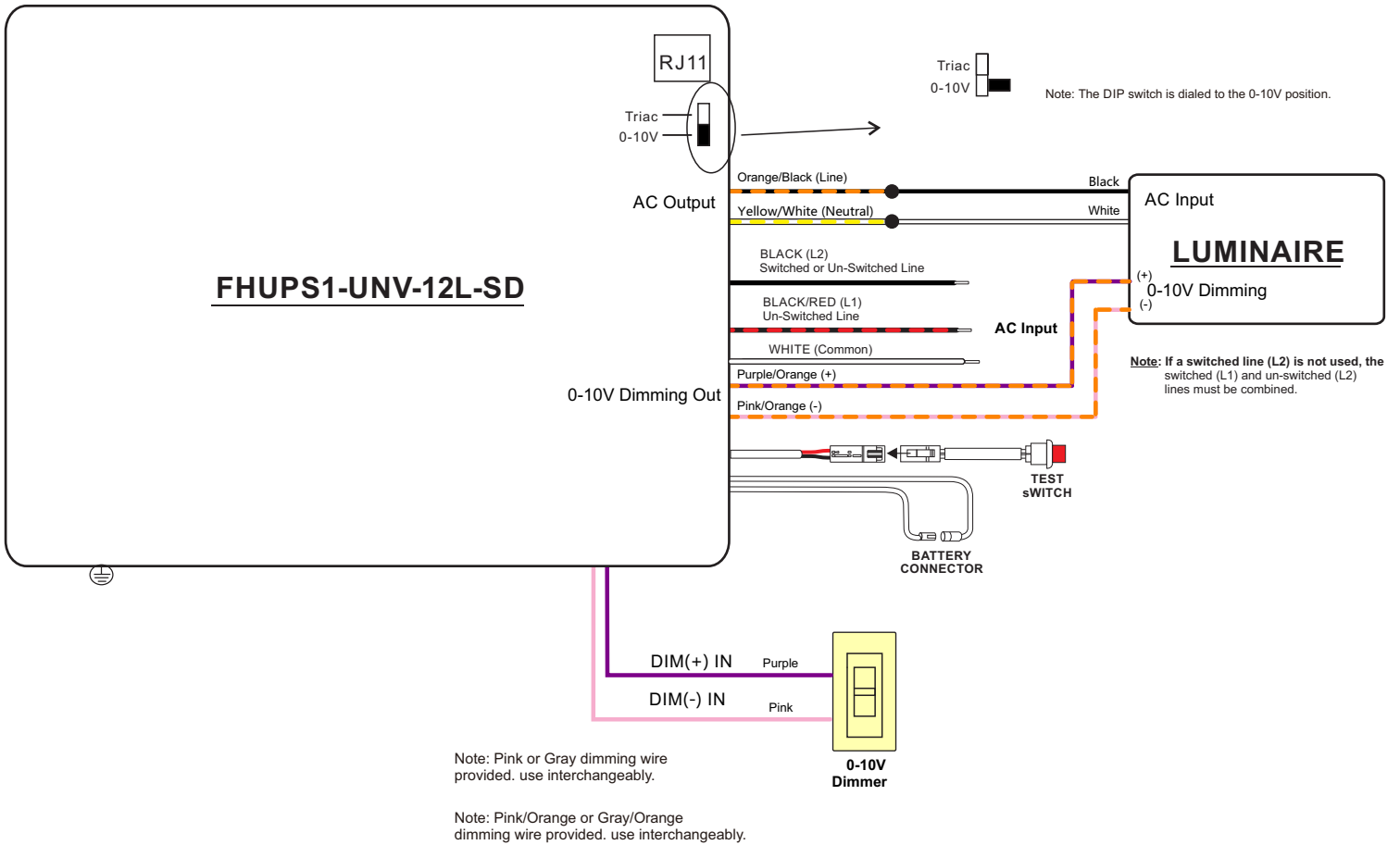

FHUPS1-UNV-12L-SD



IP20

RoHS COMPLIANT



UL US LISTED E313578 EMER. POWER EQ.

Wiring Diagram 3

For Luminaire(s) with an output power less than 100W and 0-10 dimming function but 0-10V dimming is not used during normal operation.

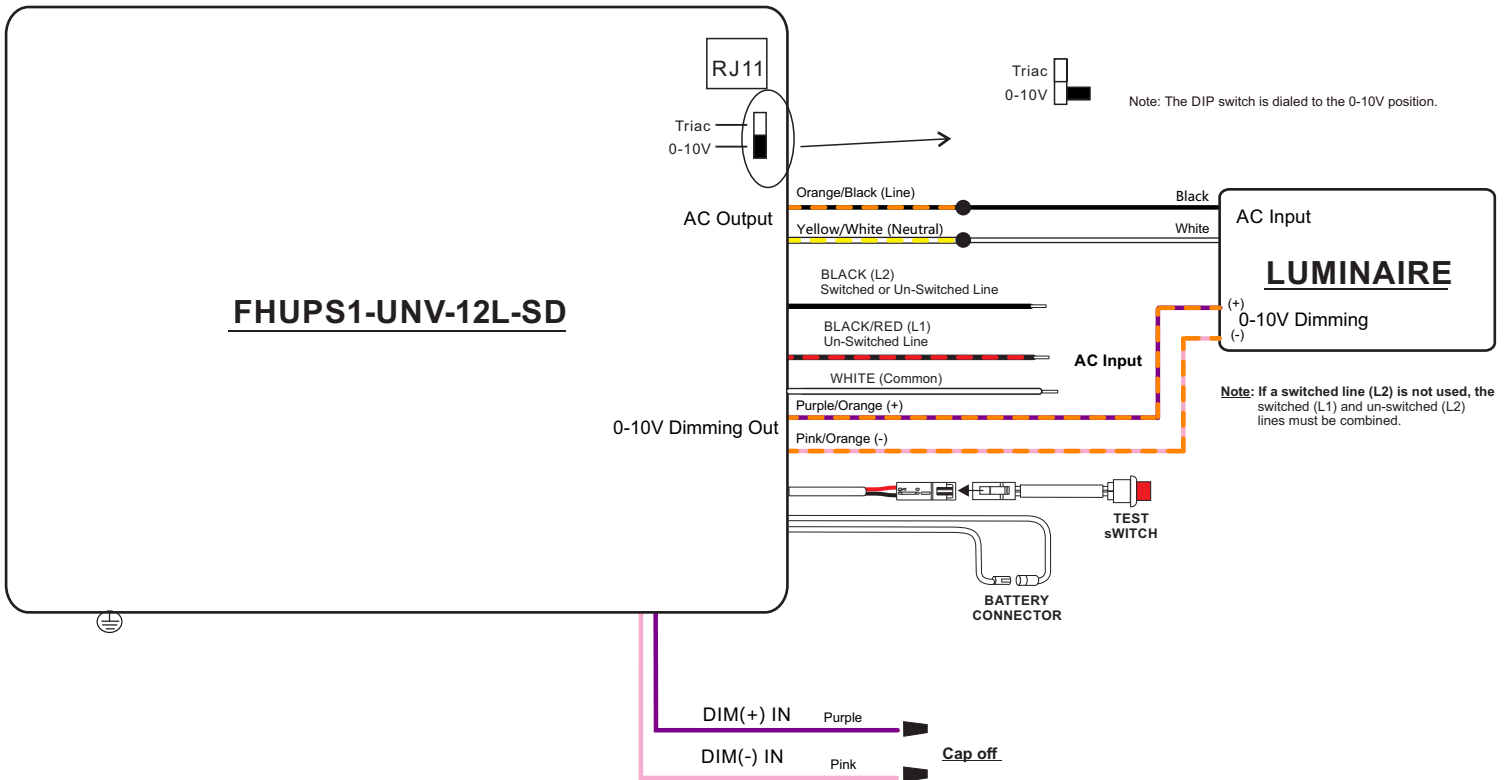

Note: Pink or Gray dimming wire provided. use interchangeably.

Note: Pink/Orange or Gray/Orange dimming wire provided. use interchangeably.



IP20

RoHS COMPLIANT



UL US LISTED E313578 EMER. POWER EQ.

Wiring Diagram 4

For Luminaire(s) with an output power less than 18W (30VA) and TRIAC dimming function.

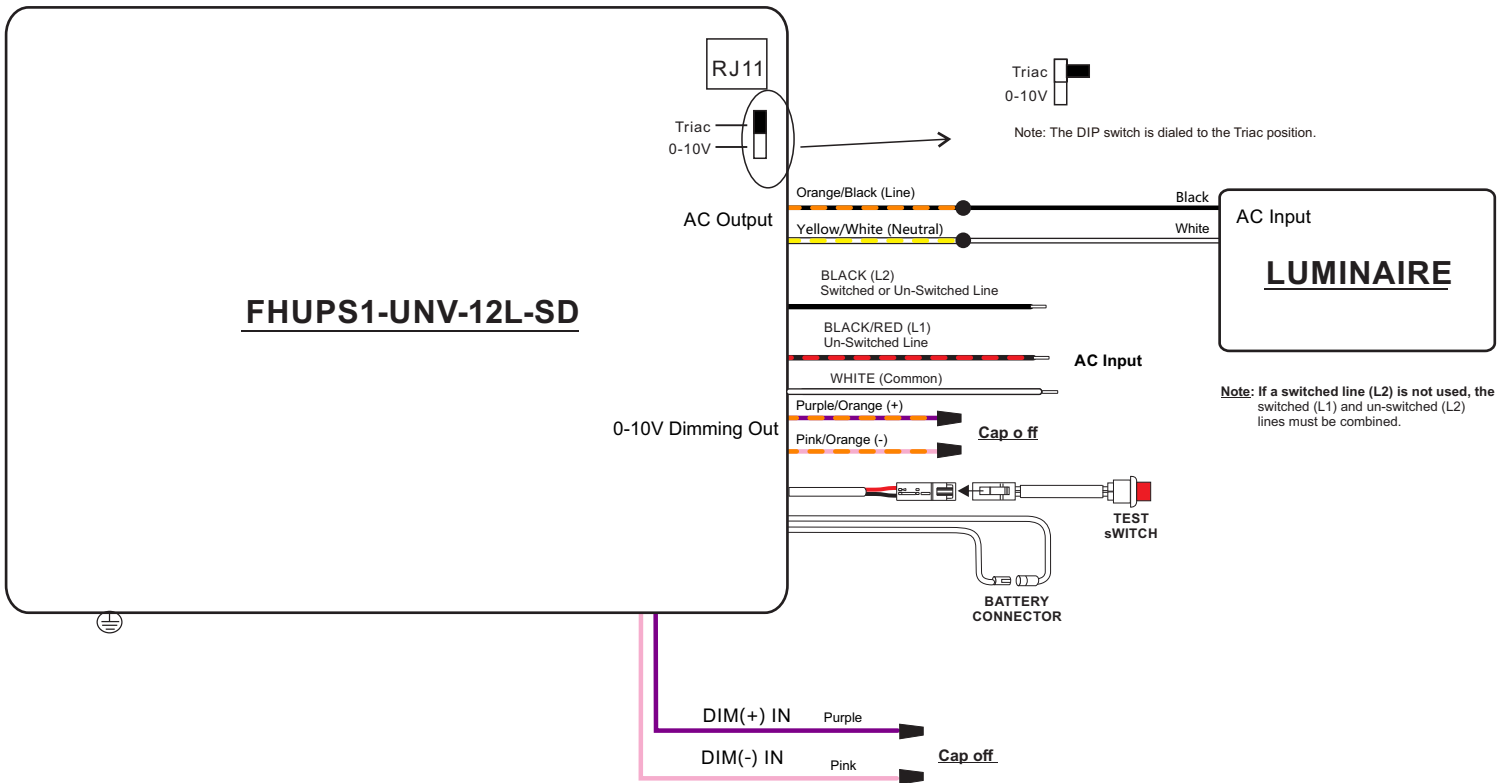

Note: Pink or Gray dimming wire provided. use interchangeably.

Note: Pink/Orange or Gray/Orange dimming wire provided. use interchangeably.



IP20

RoHS COMPLIANT



UL US LISTED E313578 EMER. POWER EQ.

Wiring Diagram 4

Wiring one single luminaire without 0-10V dimming

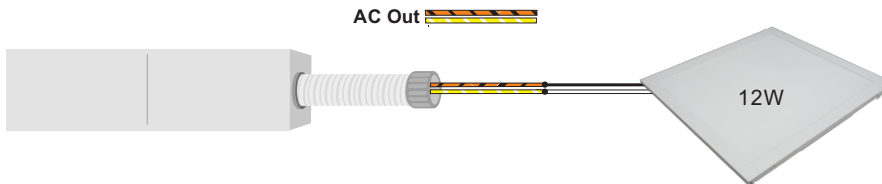

- One 12W luminaire powered at 100% during emergency

Wiring Diagram 5

Wiring multiple luminaires without 0-10V dimming

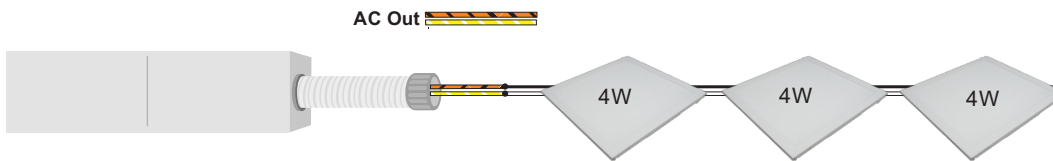

- Three 4W luminaires powered at 4W each during emergency

Wiring Diagram 6

Wiring multiple luminaires with 0-10V dimming

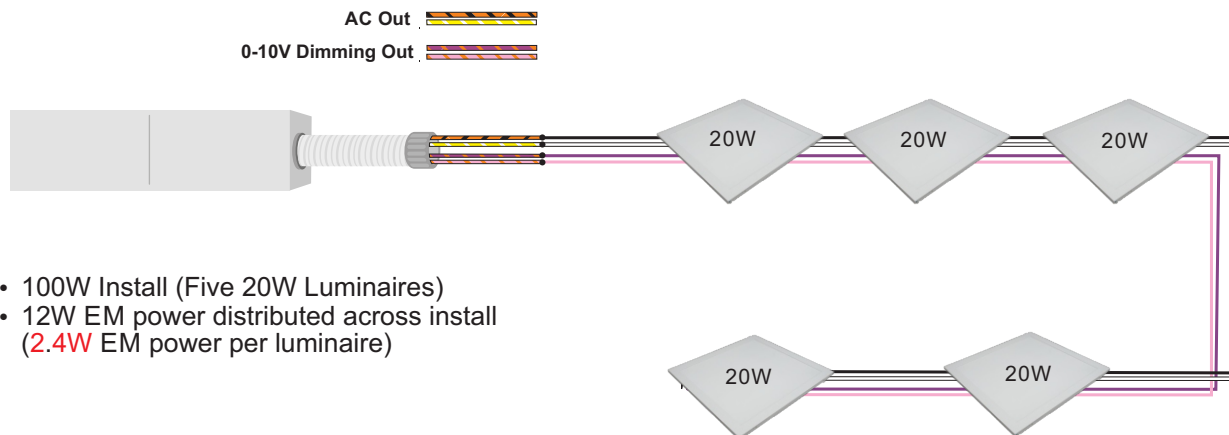

- 100W Install (Five 20W Luminaires)
- 12W EM power distributed across install (2.4W EM power per luminaire)



FHUPS1-UNV-12L-SD

IP20

RoHS COMPLIANT



UL US LISTED E313578 EMER. POWER EQ.

TEST SWITCH INDICATOR STATUS:

LED Indicators Status	EM Driver Status / Mode
● Solid Green	System OK/AC OK(Self-Diagnostic Enable or Disabled)
⦿ Slow Flashing Red, 4s on/1s off	Battery Not detected, check battery switch or connection
⦿ Flashing Red, 1s on/1s off	Battery Failure, replace battery
⦿ Flashing Green, 1s on/1s off	Self-Diagnostic test underway
⦿ Slow Flashing Green, 0.1s on/3s off	Normal working in EM mode
⦿ Flashing Green, 2s on/0.5s off	Enables Self-diagnosis
⦿ Flashing Green, 0.5s on/2s off	Cancel Self-diagnosis
⦿ Flashing Red, 4s on/4s off	Abnormal over power Under Self-diagnosis/Power exceeds or drops below 12W during discharge Under self-diagnostic mode
⦿ Flashing Red, 0.5s on/3s off	Self-diagnosis process Low Voltage fault/Output power has deviated +/- 10% during discharge Under self-diagnostic mode

TEST SWITCH OPERATIONS:

- 1.EM Test: Press and hold the test button (>1s) to enter EM mode in normal AC powered.
 - 2.Manual Self-Diagnostic:Battery voltage greater than 11.85V ,or change for 12 hours. Quickly press the test button three times within three seconds to force the controller enter a Self-Diagnostic cycle.
 - 3.Enable/Disable Auto Self-Diagnostic: Press the test button once quickly. Then release and then press and hold the test button for 2s and then release.When properly executed the indicator on the test button will display the appropriate Enable/Disable status.A flashing of 2s ON/0.5s OFF means“Enabled”, while a flashing of 0.5s ON/2s OFF means“Disabled”. Once Enable/Disable is set the status color on the test button will remain the same throughout normal operation (refer to Indicator StatusTable).
- Check the current status: Press the button twice within 2 seconds. If the LED Indicator Status is 2s on/0.5s off, the current state is enabled. If the LED Indicator Status is 0.5s on/2s off, the current status is self-diagnostic disabled.

Emergency Battery Disconnect:

Press and hold the test switch for 5 seconds during EM output condition to turn off EM output. This is useful for production environment to turn off the EM output once a luminaire has completed functionality testing. Emergency output will return to normal after the mains power is restored.

FHUPS1-UNV-12L-SD



IP20

RoHS COMPLIANT



UL US LISTED E313578 EMER. POWER EQ.

Programming:

The FHUPS1-UNV-12L-SD is programmed through the program wire on the emergency driver with the TPSB-100 programmer. Unless otherwise programmed the output will self-program to the maximum rating of the battery. Customer must use the programming harness and programming block that comes with the TPSB-100.

Programming Wire Diagram

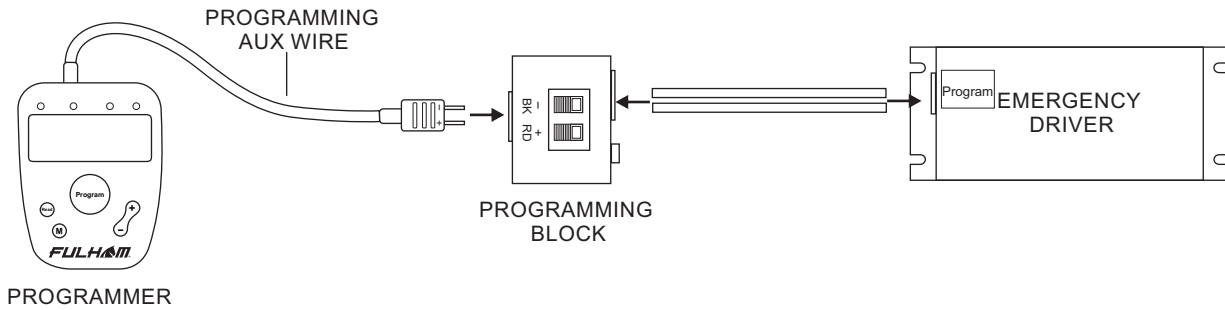

Programming Features

- Output EM Power
- * Enable / Disable Self-Diagnostic



SmartSet Software



TPSB-100 SmartSet Controller

* For more detailed programming instructions please see our Programming Instructions and Design Guide found on our website:

- <https://www.fulham.com/PDFs/SpecSheets/Fulham-Design-Guide-Programmable-Drivers.pdf>



FHUPS1-UNV-12L-SD

IP20

RoHS
COMPLIANT



Lithium-ion



EMER. POWER EQ.

Run time at low power output:

TBD

Power(W)	Run time(min)
6W	>160
7W	>140
8W	>125
9W	>115
10W	>106
11W	>98
12W	>90



FHUPS1-UNV-12L-SD



IP20



Access test reports and status reports on any browser

Phone, tablet, or pc

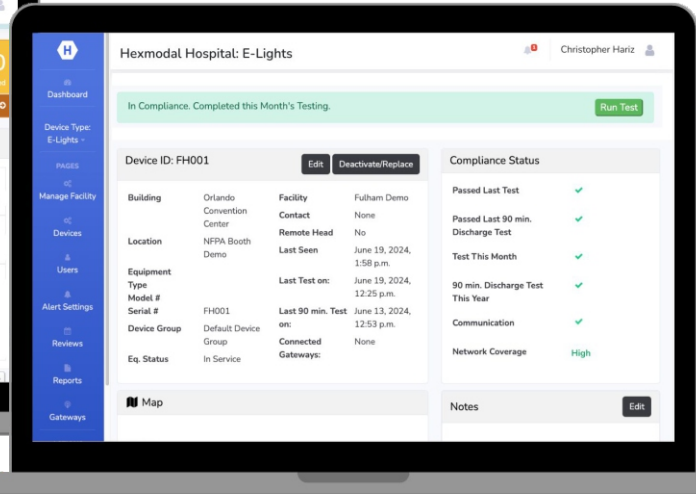
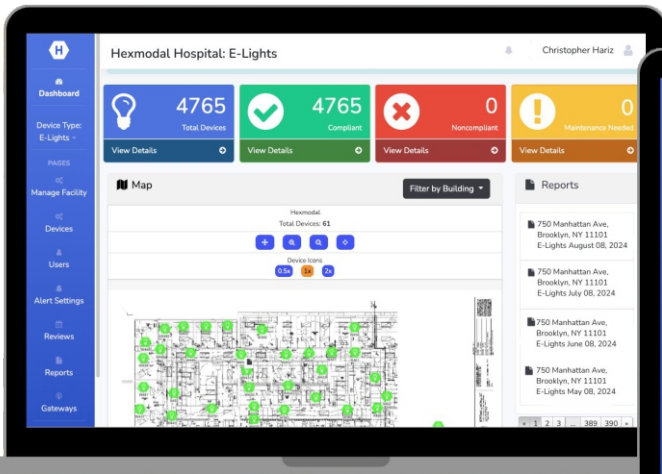

For ceiling E-Light Luminares 2X4 & 2X2 troffers

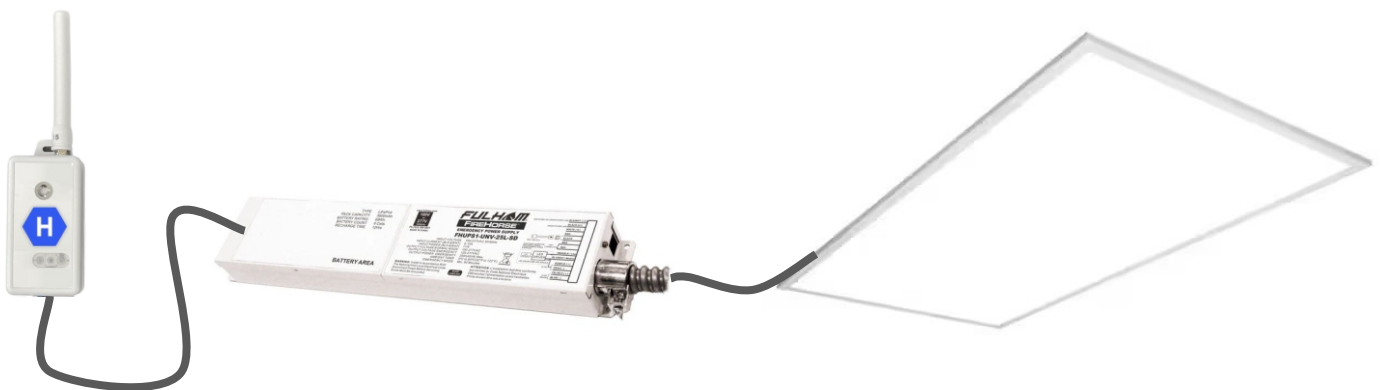

Hexmodal Smart Dongle and Microinverter converts any ceiling e-light into a smart self-testing luminaire.



info@hexmodal.com | 201.754.8048 | 750 Manhattan Ave New York, NY



FHUPS1-UNV-12L-SD



IP20



No IT Needed. Simple. Independent. Secure

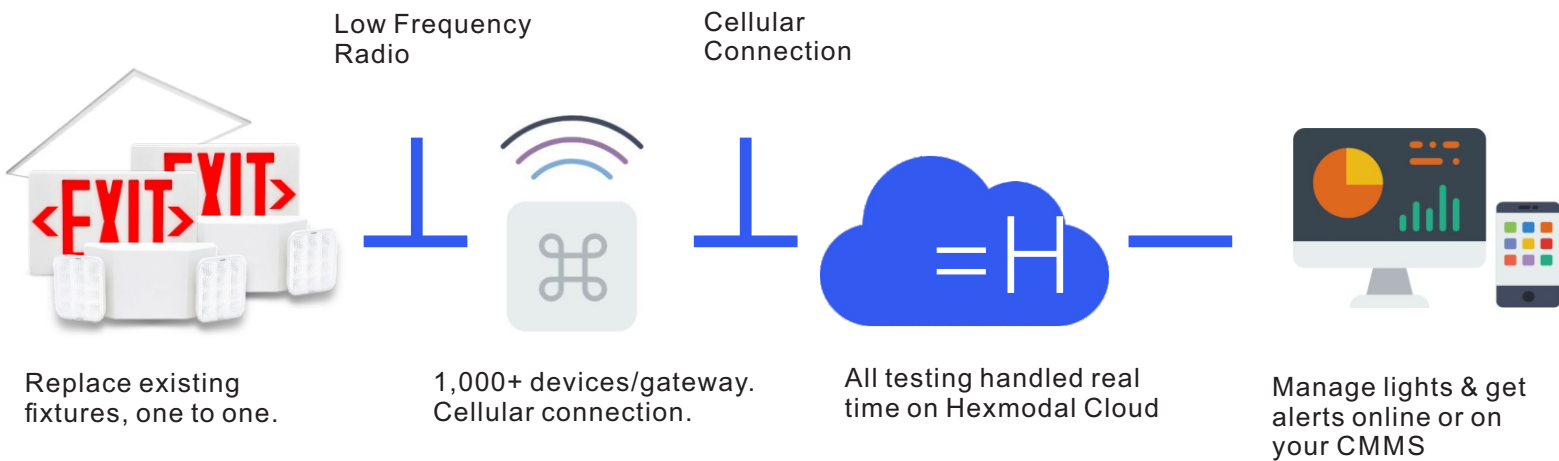

info@hexmodal.com | 201.754.8048 | 750 Manhattan Ave New York, NY



FHUPS1-UNV-12L-SD



IP20



GENERAL INSTALLATION GUIDELINES FOR LED EMERGENCY MICRO INVERTER

IMPORTANT SAFE PRACTICES

When using electrical equipment and this lighting device basic safety precaution should be followed at all times including but not limited to the following:

PLEASE READ CAREFULLY AND FOLLOW ALL INSTRUCTIONS FOR YOUR OWN SAFETY

IMPORTANT: Do not connect battery until fixture is installed.

IMPORTANT: An un-switched AC power source of 100VAC to 277VAC is required.

This device is designed for use in fixtures listed for dry and damp locations.

CAUTION: Make sure all electrical connections conform to the National Electrical Code and all applicable local regulations.

ATTENTION : Assurez-vous que toutes les connexions électriques sont conformes au Code national de l'électricité et à toutes les réglementations locales applicables.

CAUTION Do not let power supply cords touch hot surfaces.

ATTENTION : Ne laissez pas les cordons d'alimentation toucher des surfaces chaudes.

CAUTION Do not mount near gas or electric heaters.

ATTENTION : Ne montez pas à proximité de radiateurs à gaz ou électriques.

CAUTION: Do not use outdoors.

ATTENTION : Ne pas utiliser à l'extérieur.

CAUTION: Battery is rechargeable Ternary Lithium Battery type and must be recycled or disposed of properly. Do not use this emergency driver with accessory equipment other than recommended by manufacturer; failure to follow this may cause an unsafe condition. Servicing should only be performed by qualified service personnel. Do not use this emergency driver for other than intended use.

ATTENTION : La batterie est de type batterie au lithium ternaire rechargeable et doit être recyclée ou éliminée correctement. N'utilisez pas ce pilote d'urgence avec des accessoires autres que ceux recommandés par le fabricant ; Le non-respect de cette consigne peut entraîner une situation dangereuse. L'entretien ne doit être effectué que par du personnel de service qualifié. N'utilisez pas ce pilote d'urgence à d'autres fins que celles prévues.

CAUTION: Equipment should be mounted in locations and at heights where it will not readily be subjected to tampering by unauthorized personnel.

ATTENTION : L'équipement doit être monté dans des endroits et à des hauteurs où il ne sera pas facilement soumis à des manipulations par du personnel non autorisé.

CAUTION: For use with a metal enclosed wiring system.

ATTENTION : À utiliser avec un système de câblage fermé en métal.

CAUTION: Sealed unit. Battery not replaceable. Replace entire unit when necessary.

ATTENTION : Unité scellée. Batterie non remplaçable. Remplacer l'unité entière si nécessaire.

SAVE THESE INSTRUCTIONS



FHUPS1-UNV-12L-SD



IP20



Lithium-ion



GENERAL INSTALLATION GUIDELINES FOR LED EMERGENCY MICRO INVERTER

IMPORTANT SAFE PRACTICES

When using electrical equipment and this lighting device basic safety precaution should be followed at all times including but not limited to the following:

IMPORTANT: The output EM power will be the maximum of connected battery unless programmed to a lesser value. EM output power will not exceed the battery rating.

IMPORTANT: Indicator (LED light) illuminated indicates battery in charge mode when AC power is applied. It is recommended and required by applicable code to test emergency function to ensure proper operation of the system; push the test switch for sixty (60) seconds every 30 days to ensure the emergency driver is functioning as LED light source illuminated. Conduct a ninety minute (90) discharge test one time (1) per year; LED light source should be illuminated for a minimum of ninety minutes (90).

ASSEMBLY and FIELD INSTALLATION WIRING: WARNING: AC power must be off before proceeding with assembly or installation of emergency driver.

ATTENTION : RISQUE DE CHOC - COUPER L'ALIMENTATION NORMALE ET DE SECOURS AVANT DE PROCÉDER À L'ENTRETIEN.

CAUTION: Install In Accordance With the National And Local Electrical Code. Disconnect Power Before Servicing. Driver Must Be Grounded. For use with a metal enclosed wiring system

ATTENTION: L'installation doit être conforme aux normes du Code National Électrique. Débranchez l'alimentation avant l'entretien. Pilote doivent être mis à la terre.

CAUTION: This equipment has not been evaluated to determine its effect on equipment or systems to which it may be connected. Loads connected to this equipment should be evaluated together with this equipment to determine reliable operation of the combination.

ATTENTION: Cet équipement n'a pas été évalué pour déterminer son effet sur l'équipement ou les systèmes auxquels il peut être raccordé. Les charges reliées à cet équipement doivent être évaluées en même temps que cet équipement afin de déterminer le fonctionnement fiable de la combinaison.

TESTING SYSTEM: The emergency battery requires a charge minimum of one (1) hour before testing the circuit. A full charge requires twelve (12) hours (Refer to battery chart).

IMPORTANT: In order to maintain proper operation and warranty coverage, the battery must be recharged once per year prior to installation.

Fulham Head Quarters:
Fulham Co., Inc
12705 South Van Ness Ave.
Hawthorne, CA 90250

SAVE THESE INSTRUCTIONS



FHUPS1-UNV-12L-SD

IP20RoHS
COMPLIANT

Guidelines

Grounding

- Inverter must be grounded by means of the inverter case.

Overload Protection

- If the maximum output power exceeded, the inverter will be switched off automatically; after the elimination of the overload, the normal operation will be restored automatically.
- If it is overloaded during emergency, it needs to be AC powered again after triggering the protection.

Load

- Fulham FHUPS1-UNV-12L-SD inverter can operate a maximum 12W, PF>0.4 (30VA) load with no 0-10V dimming function; or it can also operate a maximum 100W (125VA) load with 0-10V dimming function, and the dimming function is required to be able to dim the load below 12W(30VA).

Short-circuit protection

- In case of a short circuit, the inverter switches to protection mode. After the removal of the short-circuit the inverter will recover automatically.
- In case of short circuit during emergency, power on again after the short circuit fault is removed.

Under-Voltage protection

- When the line voltage is reduced to the critical voltage, the inverter will instantly provide emergency power to the load.

Hot Swapping

- This inverter does not support hot swapping of the LEDs

Remote Mounting

- Up to 164ft (50m) with 18AWG. Contact Fulham for higher remote distance.

Battery Maintenance

- In order to maintain proper operation and warranty coverage, the battery must be recharged once per year prior to installation.

Warranty

- Reference Fulham's limited Warranty: <https://cdn.fulham.com/PDFs/Limited-Warranty.pdf>



FHUPS1-UNV-12L-SD

IP20

RoHS COMPLIANT



UL US LISTED E313578 EMER. POWER EQ.

Part Number Matrix

FH **UPS** **1** **UNV** **12** **L** **SD**

FH = Fire Horse

UPS= Uninterruptible Power Supply

1 = UPS Order Number

Input Voltage

UNV= 100V-277V

Maximum Output Power

12 = 12W

Case Type

L= Long or Linear

Additional Options

SD= Self Diagnostic

Product Image:

FHUPS1-UNV-12L-SD



Packaging

Master Carton

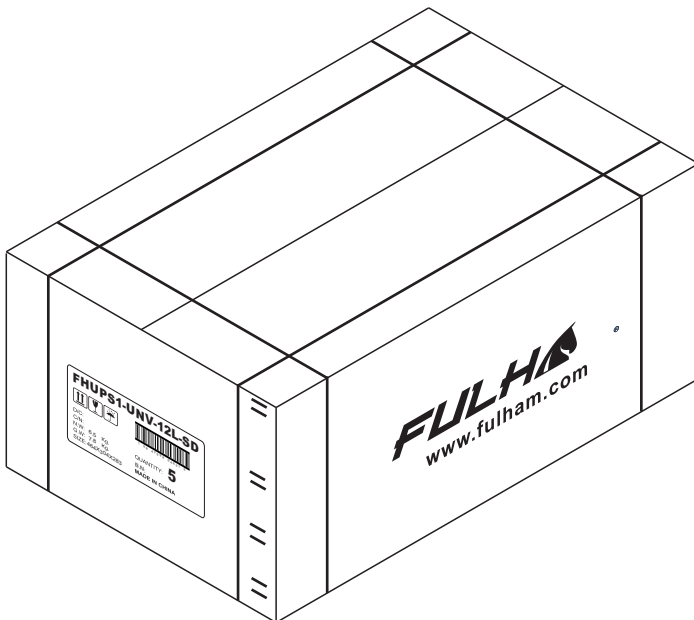

OUTER DIMENSION		
L	W	H
464mm (18.27")	304mm (11.97")	283mm (11.14")
Net Weight	Gross Weight	QUANTITY
6.5kg 14.33bls	7.8kg 17.2bls	5