

PHILIPS
bodine

Auxiliary Power

Generator Products

GTD20A



Lighting Relay Control Device
Maximum Lighting Load of 20A
Universal Input

Product order number: GTD20AM

Project: _____
Type: _____
Model No: _____ Qty: _____
Date: _____
Notes: _____

Specifications

UL Listed for US and Canada

Field Installation
(Indoor and Damp)

Full Warranty

5 Years (NOT pro-rata)

Universal Input Voltage

120 Through 277 VAC, 50/60 Hz

AC Input Current

45 mA
(Sensing Circuit Only)

AC Input Power Rating

4.0 Watts
(Sensing Circuit Only)

Approved Lighting Loads

Any Type

Lighting Load Rating

20 A Maximum

Temperature Rating (Ambient)

-20°C to +55°C (-4°F to +131°F)

Dimensions

9" x 6" x 3.5" (229 mm x 152 mm x 89 mm)
Mounting 8.5" x 2.5" (216 mm x 63.5 mm)

Weight

5 lbs. (2.3 kg)

Benefits:

- Allows generator supplied emergency lighting regardless of wall switch position
- Energy costs savings benefits by eliminating constant night lighting
- Can be used with fluorescent or LED lighting

Dimensions

9.0" x 6.0" x 3.5"

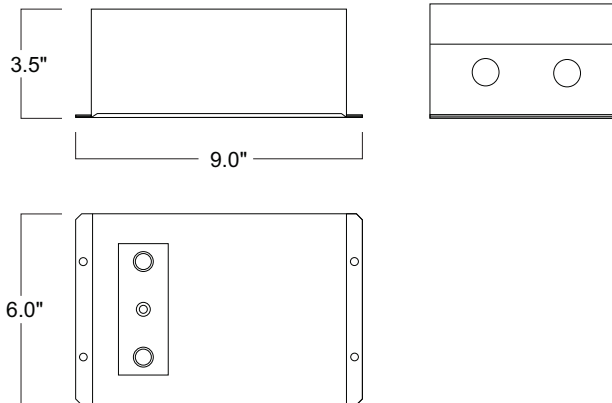

GTD20A

Lighting Relay Control Device

* WIRE GAUGES FOR ALL LEADS
TERMINATING AT T2 SHOULD BE #18 AWG.
* JUMPER CONNECTIONS ON T1 AND T2 ARE
CONTRACTOR INSTALLED.

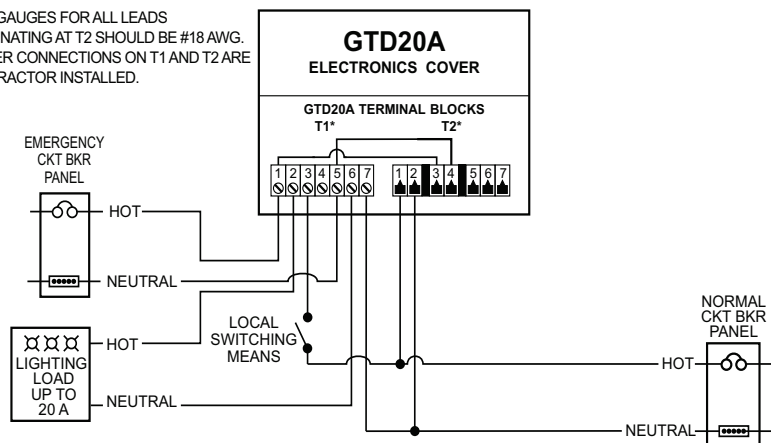

APPLICATION

The GTD20A works in conjunction with an auxiliary generator or central inverter system to power designated lighting loads up to 20 amps regardless of local switch position. The device consists of relay switching circuitry in a single, wall-mountable enclosure (T-bar mounting kit optional). The GTD20A senses the loss of normal power and, in response, switches the lighting load to a designated alternate power source. The device can be used to: (1) transfer a lighting load from normal power to generator or central inverter system power when normal power is lost; (2) bypass a wall switch to allow generator- or central inverter system-supplied lighting loads to energize when normal power is lost; (3) bypass a dimming panel and prevent backfeed to allow lighting to energize at full brightness when normal power is lost; and (4) bypass most dimming controls using an auxiliary relay contact. The GTD20A includes three dry form C contacts, which allows the user a wide variety of wiring options. For additional applications and information, contact the factory. The GTD20A is suitable for use in indoor and damp locations.

OPERATION

The GTD20A senses the loss of normal power and switches the lighting load, connecting it to a user-designated standby circuit. No routine maintenance is required to keep the GTD20A functional; however, like other life safety unit equipment, it should be checked periodically to ensure that it is working properly.

INSTALLATION

The GTD20A does not affect normal fixture operation and comes fully assembled for immediate installation. In addition to available wiring, the device requires a direct, unswitched connection to a normal power circuit and, depending on the application, an unswitched connection to a generator-supplied or central inverter system-supplied standby panel. See diagram A for typical installation.

UL and CODE COMPLIANCE

The GTD20A has been tested by Underwriters Laboratories in accordance with the standards set forth in UL 1008 for Automatic Transfer Switches for Optional Standby Systems. The GTD20A has also been tested by Underwriters Laboratories in accordance with standards set forth in CSA C22.2 No. 178 for Automatic Transfer Switches. The GTD20A is UL Listed for field installation.

SPECIFICATION

Standby lighting shall be provided by using existing lighting loads equipped with a Philips Bodine GTD20A lighting relay control device. The device shall be capable of bypassing the local switching means when normal utility power has been lost. The device shall consist of relay switching circuitry, a test switch, a normal power indicator light and an alternate power indicator light contained in one 9" x 6" x 3.5" enclosure; shall sense normal power at 120 through 277 VAC, 50/60 Hz; shall be rated for 120 through 277 VAC, 50/60 Hz at up to 20 amps of lighting load; shall draw 45 mA and 4.0 Watts during normal sensing operation; and shall comply with the current NEC. The device shall be UL Listed for field installation in indoor or damp locations and shall be warranted for a full five years from date of purchase.

WARRANTY

WARRANTY

The GTD20A generator transfer device is warranted for five (5) full years from date of purchase. Please see detailed warranty information on our web site.

© 2015 Koninklijke Philips N.V. All rights reserved. Philips reserves the right to make changes in specifications and/or to discontinue any product at any time without notice or obligation and will not be liable for any consequences resulting from the use of this publication.

Document order number: L4100020 12.07



Philips Emergency Lighting
236 Mt. Pleasant Rd.
Collierville, TN 38017
Tech Support: 888.263.4638
Sales: 800.223.5728

philips.com/bodine