



KT-EMRG-LED-5C-500-SEN

CONSTANT-POWER EMERGENCY LED BACK-UP DRIVER

DESCRIPTION

Constant-Power Emergency LED Back-Up Driver | 5W Output | 120-277V Input | CEC T20 Compliant



DRIVER TYPE: Constant-Power Emergency LED Back-Up Driver
MAX. OUTPUT POWER: 5W
INPUT VOLTAGE: 120-277Vac ±10%
NUMBER OF OUTPUTS: One
SAFETY STANDARD: UL 924, Complies with CEC Title 20 Efficiency Standards
LOCATION: IP20 design for dry and damp locations
WARRANTY: 5 Years

ELECTRICAL SPECIFICATIONS

Input voltage range	120~277Vac ± 10%
Frequency	50/60Hz
Power factor	> 0.5 under 120~277Vac input
Inrush current	7A @230V
Max input current	50mA @120V, 35mA @240V, and 30mA @277V
THD	< 170% under 120~277Vac input
Output voltage	20-60Vdc Class 2 compliant Remarks: The output power is valid for output voltage ≤ 58V; above that, power will drop
Output current	250mA @ 20Vdc, 86mA @ 58Vdc
Output power	5W (constant)
Turn-on Delay Time	< 1s
Overshoot	< 10%
Ripple & Noise (pk-pk)	< 10%
Withstand voltage	Input to output, 2800Vdc, 2mA
Leakage current	Maximum 0.5mA at 277Vac, 60Hz input
Protection	Over-voltage protection: Hiccup mode. Protection will trigger when load voltage exceeds specified output voltage and will auto recover after the fault mode is removed. Over-current protection: Hiccup mode. Protection will trigger when load current exceeds specified output current and will auto recover after the fault mode is removed. Short-circuit protection: Hiccup mode. Protection will trigger when short circuit and will auto recover after the fault mode is removed.
Emergency Operation	90 minutes
Battery	High-temperature, maintenance-free, LiFePO ₄ battery, 9.6Vdc, 3 cell
Recharge Time	24 hours
Battery Charging Current	307mA



KT-EMRG-LED-5C-500-SEN

CONSTANT-POWER EMERGENCY LED BACK-UP DRIVER

ENVIRONMENTAL SPECIFICATIONS

Operating temperature	0°C/32°F to 55°C/131°F
Storage temperature	-20°C/-4°F to 55°C/131°F
Humidity	5% to 95%
MTBF	284,000 hours at 40°C/104°F ambient (~55°C/131°F case temp)
Life rating	97,500 hours at 120Vac input, 100% load and 55°C/131°F case temp
Maximum ambient temperature	55°C/131°F

SAFETY AND EMC COMPLIANCE

UL/cUL	UL 924, Complies with CEC Title 20 Efficiency Standards
FCC, 47CFR Part 15	ANSI C63.4:2009 Class B (consumer limit)
EN61000-3-2	Harmonic current emissions Class C

PHYSICAL SPECIFICATIONS

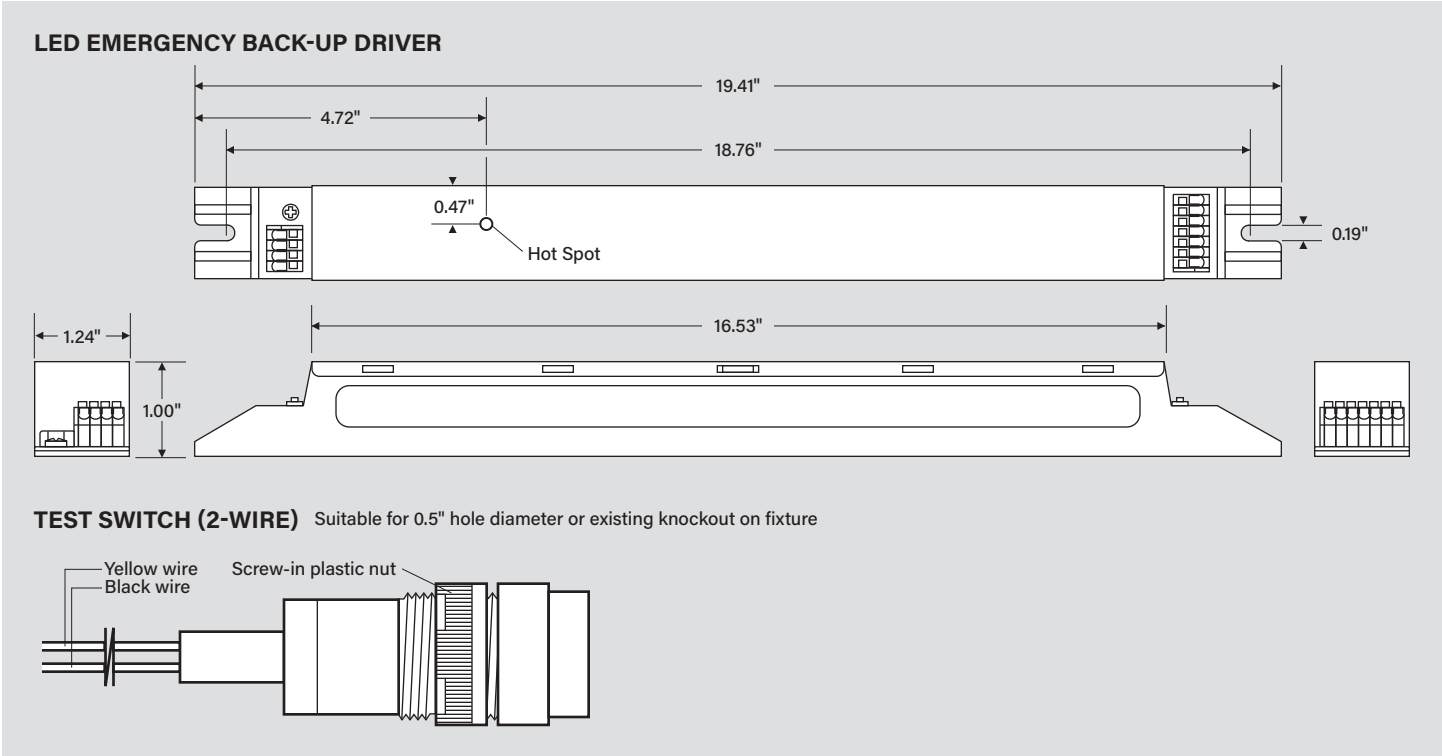



KT-EMRG-LED-5C-500-SEN

CONSTANT-POWER EMERGENCY LED BACK-UP DRIVER

WIRING DIAGRAM

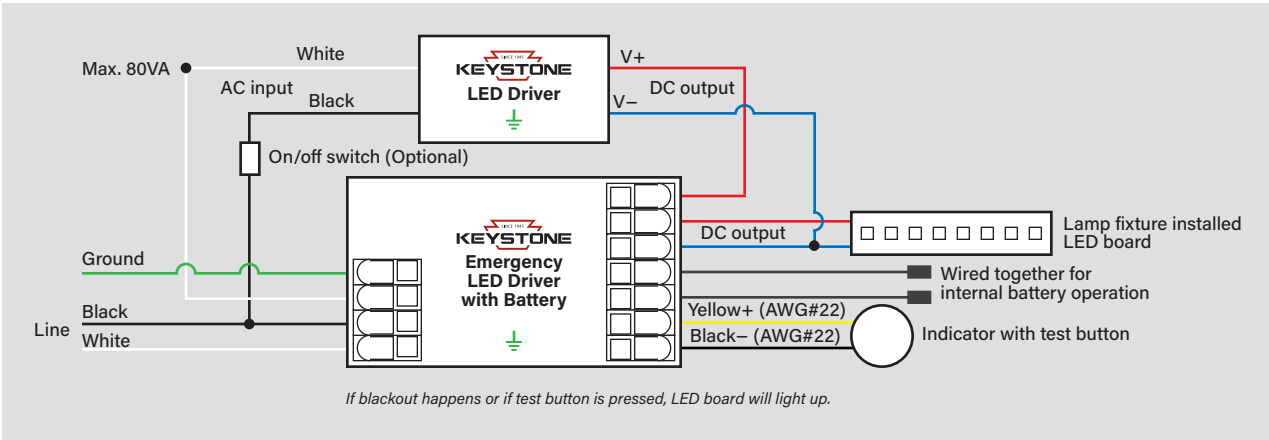

ORDERING INFORMATION

ORDER CODE	DESCRIPTION	PACK QTY.	ITEM STATUS
KT-EMRG-LED-5C-500-SEN	LED Emergency Back-Up Driver, CEC Compliant	12	Active

CATALOG NUMBER BREAKDOWN

KT-EMRG-LED-5C-500-SEN

- 1
- 2
- 3
- 4
- 5
- 6
- 7
- 8

- 1** Keystone Technologies
- 2** Emergency Back-Up
- 3** LED Driver
- 4** Nominal Wattage
- 5** CEC Compliant
- 6** Nominal Lumen Output
- 7** Slim Case
- 8** 1-Piece Enclosure