

DESCRIPTION

The Cielo series of LED drivers generate one constant current output from an AC input. Dual Dimming allows the Cielo high efficiency drivers to be used with compatible 0-10V or TRIAC/ELV dimmers.



KEY FEATURES

- 120/220-240/277V_{AC} Input
 - Dims with TRIAC and ELV dimmers at 120V_{AC} only
 - Dims with industry standard 0-10V dimmers (108-305V_{AC})
 - Max Output Power: 10W to 50W
 - 2 case sizes, 10-30W and 40-50W
 - Efficiency up to 84%
 - 90°C Top case rated
 - <20% THD, >0.9 PF
 - Fast start up time
 - UL 8750 Approved, LVLE outputs*. Class II isolation
 - Long Life
 - RoHS Compliant
- *UL Class 2 under evaluation



APPLICATIONS AND BENEFITS

Cielo LED drivers are designed for powering LED luminaries using standard lighting controls. Their discreet size easily fits into the space constrained LED fixtures of today's growing Commercial, Residential and Architectural lighting markets.

The modules operate with:

- Standard Light Switches
- 0-10V Dimmers
- Triac based Incandescent Dimmers (Forward phase – leading edge)
- Electronic Low Voltage Dimmers (Reverse Phase – trailing edge)

The following diagram depicts a typical installation utilizing the Cielo:

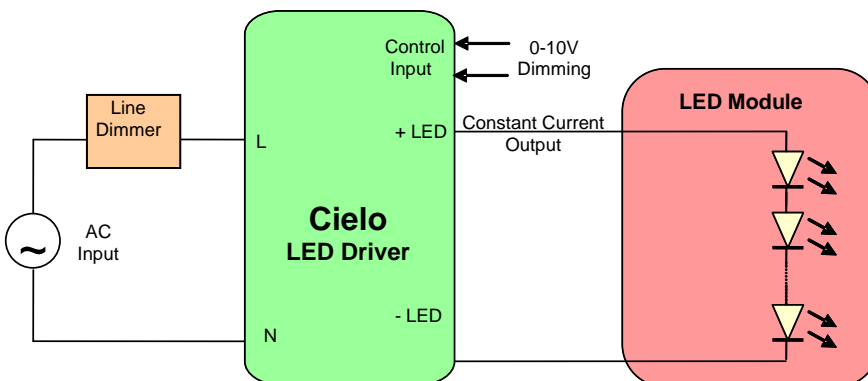

Cielo's Dimming Options:

- Analog Dimming (0-10V) input provides 10-100% lout Dimming
- AC line dimming from Triac or ELV dimmers (120V_{AC})
- Dimming range down to less than 10% nominal output current

MODEL CODING AND OUTPUT RATINGS

	Model Number	Pout Max (W)	Iout (mA)	Vout Min (V _{DC})	Vout Max (V _{DC})	Vout No_Load
10 to 30W Housing						
10 - 15W	RCL010-0250A	10.5	250	24	42	50
	RCL015-0300A	12.6	300	24	42	50
	RCL015-0350A	14.7	350	24	42	50
	RCL015-0350B	11.2	350	21	32	41.6
	RCL015-0440A	15.0	440	24	34	44.2
	RCL015-0440B	11.0	440	19	25	32.5
16 - 20W	RCL020-0350A	19.6	350	40	56	60
	RCL020-0450A	18.9	450	24	42	50
	RCL020-0500A	16.0	500	21	32	41.6
	RCL020-0600A	16.2	600	20	27	35
	RCL020-0700A	16.8	700	14	24	31.2
21 - 30W	RCL030-0500A	21.0	500	24	42	50
	RCL030-0550A	23.1	550	24	42	50
	RCL030-0620A	26.0	620	24	42	50
	RCL030-0700A	22.4	700	21	32	41.6
	RCL030-0700B	29.4	700	24	42	50
	RCL030-0700C	27.3	700	27	39	50
	RCL030-0900A	24.3	900	20	27	35
	RCL030-0900B*	28.8	900	21	32	41.6
	RCL030-1100A	29.7	1100	20	27	35



*This product is only UL approved, no CB and no ENEC.

	Model Number	Pout Max (W)	Iout (mA)	Vout Min (V _{DC})	Vout Max (V _{DC})	Vout No_Load
31 to 50W Housing						
31 - 40W	RCL040-0700B	39.2	700	40	56	60
	RCL040-0800A	33.6	800	24	42	50
	RCL040-0850A	35.7	850	24	42	50
	RCL040-0900A	37.8	900	24	42	50
	RCL040-0940A	40.4	940	32	43	50
41 - 50W	RCL050-1050A	44.1	1050	24	42	50
	RCL050-1200A	50.4	1200	24	42	50
	RCL050-1400A	44.8	1400	21	32	41.6
	RCL050-1400B	47.6	1400	24	34	44.2



INPUT SPECIFICATIONS

Specification	Test Conditions / Notes		Min.	Nominal	Max.	Units
AC Input Voltage			108	120-277	305	V _{AC}
Input Frequency			47	50/60	63	Hz
Input Current	120V _{AC} (10-30W models)		-	-	0.35	A
	120V _{AC} (31-50W models)		-	-	0.70	A
Inrush Current (10-30W models)	120V _{AC}	Half Value time: 200µs	-	-	6	Apk
	230V _{AC}	Half Value time: 150µs	-	-	12	
	277V _{AC}	Half Value time: 150µs	-	-	15	
Inrush Current (31-50W models)	120V _{AC}	Half Value time: 200µs	-	-	7	Apk
	230V _{AC}	Half Value time: 250µs	-	-	12	
	277V _{AC}	Half Value time: 250µs	-	-	14	
THD*	120V _{AC} Rated Load		-	-	10	%
	230V _{AC} Rated Load		-	-	15	
	277V _{AC} Rated Load		-	-	20	
Efficiency	31-50W models		-	84	-	%
	15-30W models		-	82	-	
	10-15W models		78	80	-	
Power Factor*	120V _{AC} Rated Load		-	0.98	0.99	
	230V _{AC} Rated Load		-	0.97	0.98	
	277V _{AC} Rated Load		-	0.95	0.96	

* please Refer to KPD for further details

OUTPUT SPECIFICATIONS

Specification	Test Conditions / Notes		Min.	Nom.	Max.	Units
Output Power Rating	10-30W models		-	-	29.7	W
	31-50W models		-	-	50.4	
Output Voltage	10-30W models		14	-	56	V
	31-50W models		21	-	56	
Output Current	10-30W models		250	-	1100	mA
	31-50W models		700	-	1400	
Ripple Current	I _{out_Pk-pk} /RMS (except for models identified in the table below)		-	-	40	%
Output Regulation			-	-	±5	%I _{out}
Start-up time	With no dimmer connected		-	300	500	ms

Model #	Ripple Current Pk-pk/RMS (%)
RCL020-0500A	55
RCL020-0600A	45
RCL020-0700A	50
RCL030-0700A	65
RCL030-0700C	45
RCL030-0700B	45
RCL030-0900A	70
RCL030-0900B	60
RCL030-1100A	70
RCL040-0940A	60
RCL050-1400A	70
RCL050-1400B	60

PROTECTION FEATURES

Specification	Test Conditions / Notes		Min.	Nominal	Max.	Units
Output Short-Circuit	Hiccup, Auto recovery		-	-	-	-
Over-Temperature Top Case	The output current of the driver will be reduced in order to limit case temperature rise, Auto recovery		-	-	>90	°C
I_{out} Over-Shoot	During power on or power off		-	-	10	%
No Load	Unit will not exceed the V _{out} Max "V _{out} No_Load" rating		-	-	V _{No_Load}	V
Isolation Primary-to-Secondary	Reinforced/double Insulation meets IEC/EN61347-2-13 Class II					

LINE DIMMING

120V_{AC} Dimming of the driver is possible with standard TRIAC based incandescent dimmers that chop the AC voltage, or with ELV dimmers. During the rapid rise time of the AC voltage when the dimmer turns on, the driver does not generate any voltage or current oscillations, and inrush current is controlled. During the on-time of the AC input, the driver regulates the output. The RMS value of the driver output current is proportional to the on-time of the AC input voltage. The RMS output current varies depending upon the conduction angle and RMS value of the applied AC input voltage.

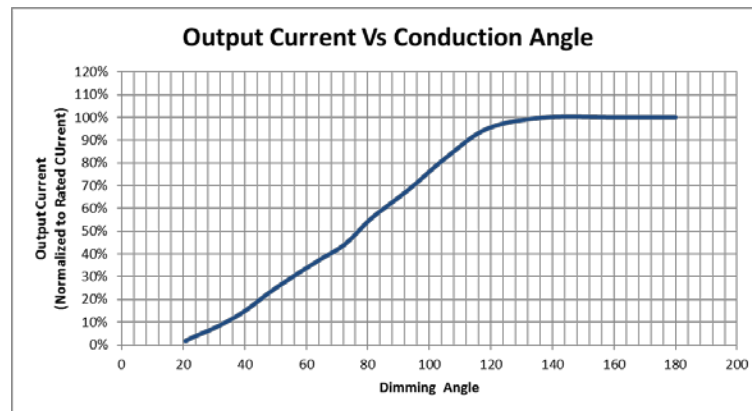
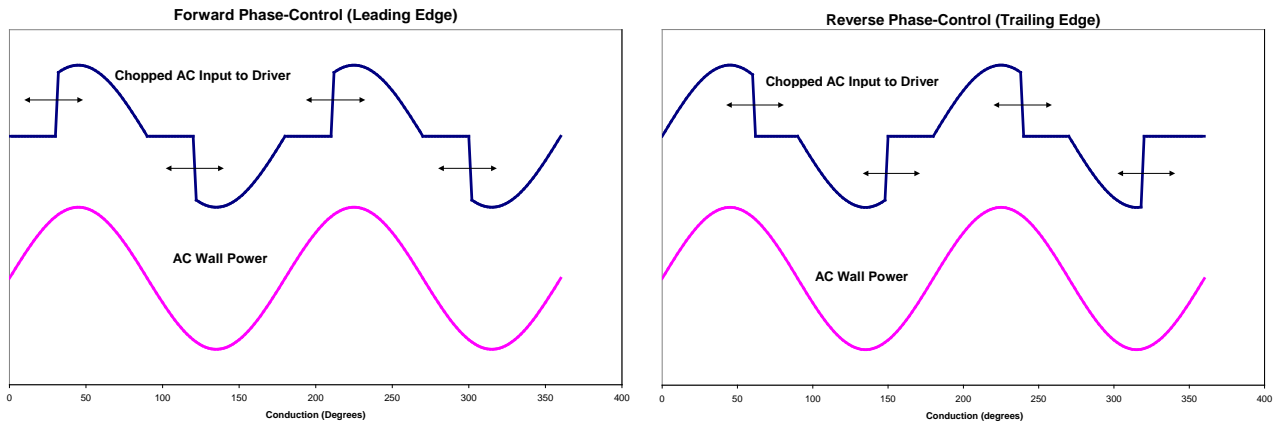

COMPATIBLE LINE DIMMERS:

120V _{AC} Dimmers only					
Mfg.	Model	Mfg.	Model	Mfg.	Model
Lutron	S-603PG	Lutron	DVELV303P	Lutron	CT103P
Leviton	IPI06-1LZ	Lutron	SELV300P	Cooper	SLC03P
Leviton	6631-2	Leviton	6683-IW	Leviton	IPE04
Lutron	DVCL-153P	Leviton	6161	Lutron	MAELV600
Lutron	DV600P	Leviton	6633-P	Lutron	FAELV500
Lutron	TGCL-153P	Lutron	TG-600P	Lightolier	ZP260QEW
Lutron	S600P	Cooper	DLC03P	Cooper	DAL06P
Leviton	VPE06	Lutron	LG600P		

0-10V DIMMING

The dimming inputs (purple/grey wires) can be used to adjust the output setting via a standard commercial wall dimmer, an external control voltage source (0 to 10VDC), or a variable resistor. Any dimmer must be capable of sinking 1mA per driver from the dimming wires. This input permits 100% to 1% dimming. With the dimming input at 1V, the output will dim to 10% of nominal current. At a dimming input of 0.1V, the output current shall decrease to 1% of nominal current.

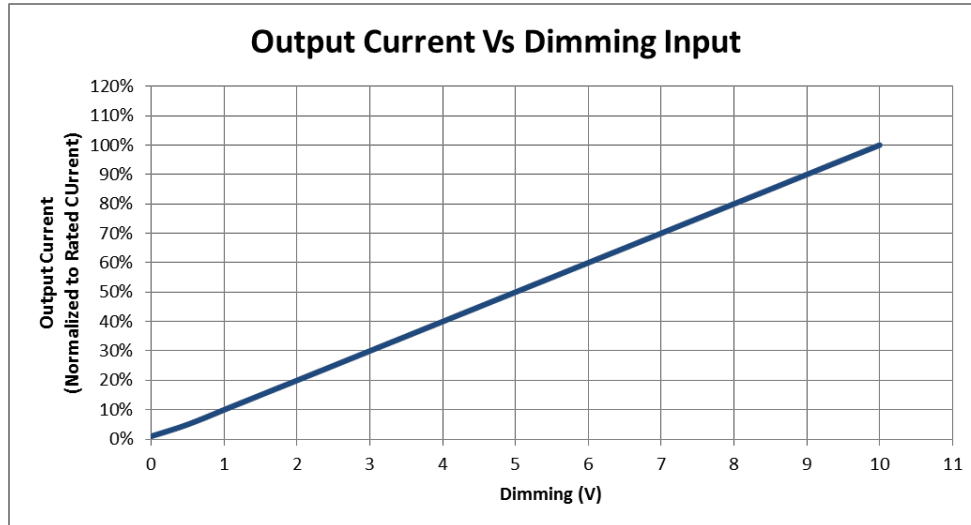

Approved Dimmers: Lutron (Part Number Nova NFTV); Lutron (Part Number Diva DVTV); Leviton (Ilumatech IP710-DL)

RESISTOR DIMMING

The following graphs show the relationship between the value of the resistor connected across the dimming input versus the output current of a single driver.

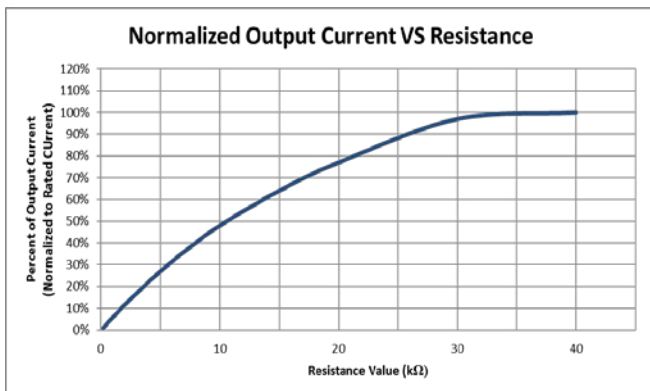

Cielo 10-30W Models

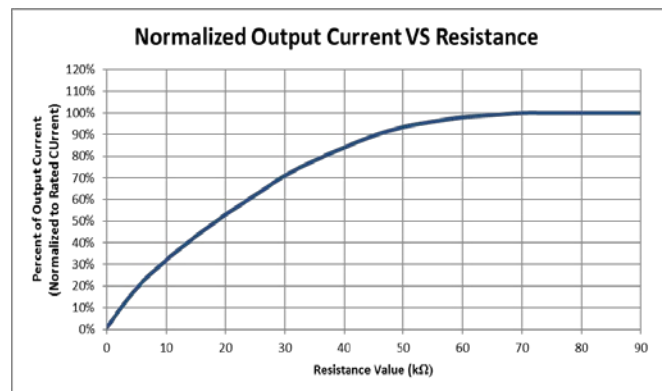

Cielo 40-50W

DIMMING NOTES

1. The length of the dimming circuit wiring, wire size and the number of drivers connected to the dimming control must be designed so that the total voltage drop is less than 0.3V between the drivers and the dimming control.
2. Line dimming and 0-10V dimming interfaces cannot be used at the same time.
3. Trimming of the output current with the resistor applied on the 0-10V wires is not permitted when using Line Dimming.

MECHANICAL DETAILS - 10W TO 30W MODELS (RCL010, RCL020, RCL030)

Enclosure Material: Plastic
 I/O Connections: Flying leads
 Ingress Protection: IP 20, UL damp rated
 Dimensions: 84 x 40 x 25.2 mm
 3.30 x 1.57 x 0.99 in

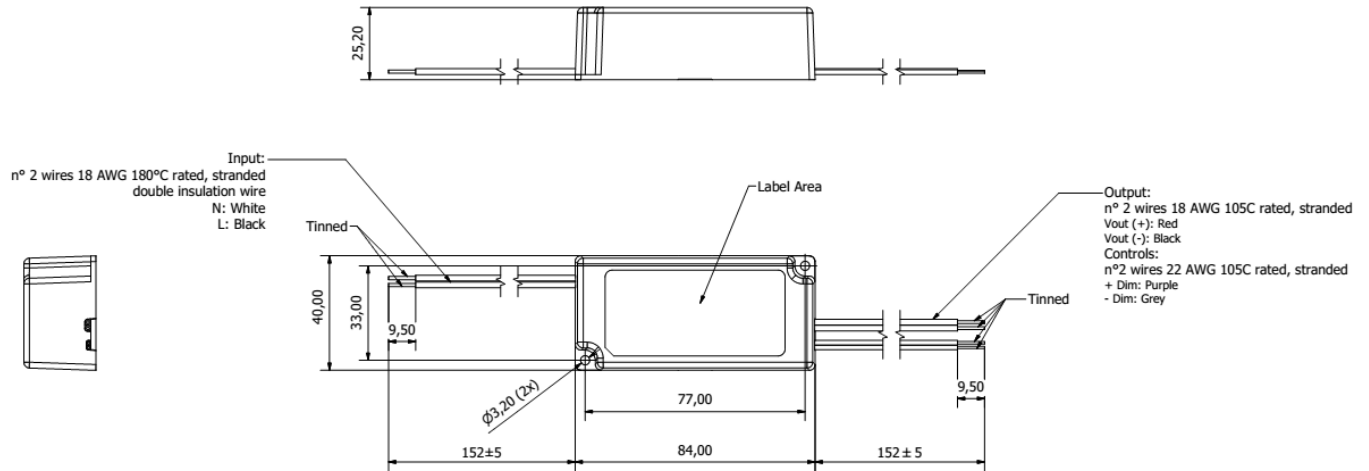

MECHANICAL DETAILS - 40W TO 50W MODELS (RCL040, RCL050)

Enclosure Material: Plastic
 I/O Connections: Flying leads
 Ingress Protection: IP 20, UL damp rated
 Dimensions: 87 x 60 x 27.2 mm
 3.47 x 2.36 x 1.07 in

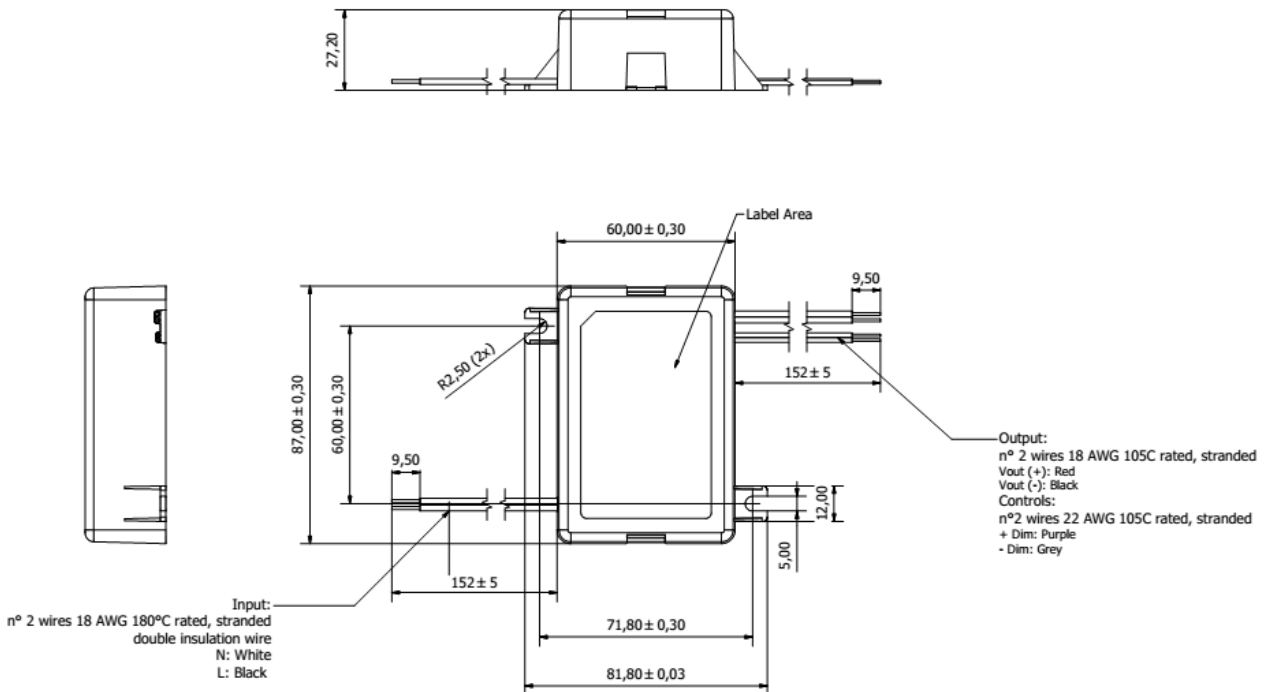

ENVIRONMENTAL SPECIFICATIONS

Specification	Test Conditions / Notes	Min	Nominal	Max	Units
Top Case Temperature Range	Refer to the Top Case measurement point	-30	-	90	°C
Storage Temperature		-40	-	85	°C
Operating Relative Humidity	Non-condensing	5	-	95	%
Surface Temperature	Exposed surfaces temperature under all operating conditions	-	-	90	°C
Cooling	Convection cooled	-	-	-	
MTBF	Rated Load, 70°C Top Case, Bellcore	250k	-	-	Hours
Useful Life	70°C Top Case.	-	50k	-	Hours





ELECTROMAGNETIC COMPATIBILITY (EMC) – EMISSIONS

Phenomenon	Conditions / Notes	Standard	Equipment Performance Class
Conducted and Radiated Emission	Test at 230V _{AC}	EN55015	
Conducted and Radiated Emission	Test at 120V _{AC}	FCC CFR47- part 15/subpart B	Class B
Conducted and Radiated Emission	Test at 277V _{AC}	FCC CFR47- part 15/subpart B	Class A
Harmonic Current Emissions		EN61000-3-2	Class C
Voltage Changes, Fluctuation and Flicker		EN61000-3-3	

ELECTROMAGNETIC COMPATIBILITY (EMC) – IMMUNITY

Phenomenon	Conditions / Notes	Standard	Note
Equipment for general lighting purposes -EMC Immunity Requirements		EN 61547	
ESD (Electrostatic Discharge)		EN 61000-4-2	
Radiated Radio-Frequency electromagnetic field		EN 61000-4-3	
Electric Fast Transient / Burst	2kV on AC input	EN 61000-4-4	
Surge	Level ±1.5kV L-N	EN 61000-4-5	
Conducted disturbances induced by Radio-Frequency fields		EN 61000-4-6	
Voltage Dips, short interruptions and Voltage Variations		EN 61000-4-11	
Non repetitive damped oscillatory transient, Ring wave		ANSI C.62.41	Category A

SAFETY AGENCIES APPROVALS

Certification Body	Safety Standards	Category
	UL Recognized ANSI / UL8750, 1 st Ed., CSA C22.2 No.250-13, 7 th Ed. Models with output voltages <60 V _{DC} include UL and CSA approval (cURus) as LVLE output. LED Driver suitable for dry and damp location	
	To obtain the “CE Declaration of Conformity” please contact info@efore.com	
	IEC/EN 61347-2-13 electronic control gear for LED Modules IEC/EN 62384 DC or AC supplied electronic control gear for LED modules – Performance Requirements	

Specifications appearing in EFORE’s catalogues and brochures as well as any oral statements are not binding. All descriptions, drawings and other particulars (including dimensions, materials and performance data) given by EFORE are as accurate as possible but, being given for general information, and are not binding on EFORE. EFORE makes thus no representation or warranty as to the accuracy of such material. We assume no liability other than as agreed in the terms of the individual contracts and we reserve the right to make technical modifications in the course of our product development. Our product information solely describes our goods and services and is in no way to be construed or interpreted as a quality or condition guarantee. The aforesaid shall not relieve the customer of its obligation to verify the suitability of our Products for the use or application intended by the purchaser. Customers are responsible for their products and applications. EFORE assumes no liability from the use of its products outside of specifications. No license is granted to any intellectual property rights by this document.