

Indoor Modular Driver



GED90MCV2P1750P

SAP:93126632

Description: Modular 90W 0-10V Class2 PSU

Input Voltage: 120V-277V ±10%

Input Frequency: 50/60Hz

Power BUS: voltage 22.5Vdc max; current 100mA max

Surge protection: 2KV/1KA

Ring wave: 3KV/100A

ROHS Compliant: Yes

Control	Max Output Power (W)	Output Current (mA)	Output Voltage (V)	Efficiency Full load @277V	Max Input Current@120Vin (A)	Max THD @Output	Min PF @Output	Max Inrush Current (A/mS)	Surge Protection	Isolated Dimming	Weight (lbs/kg)	IP Rating
									Ring Wave	Dimming Range @full load		
0-10V	90	500-1750	30-52	90%,	0.86	20% (≥22W output)	>0.9 (≥22W output)	See Page below	2KV/1KA 3KV/100A	100%-1%	1.43 / 0.65	IP54

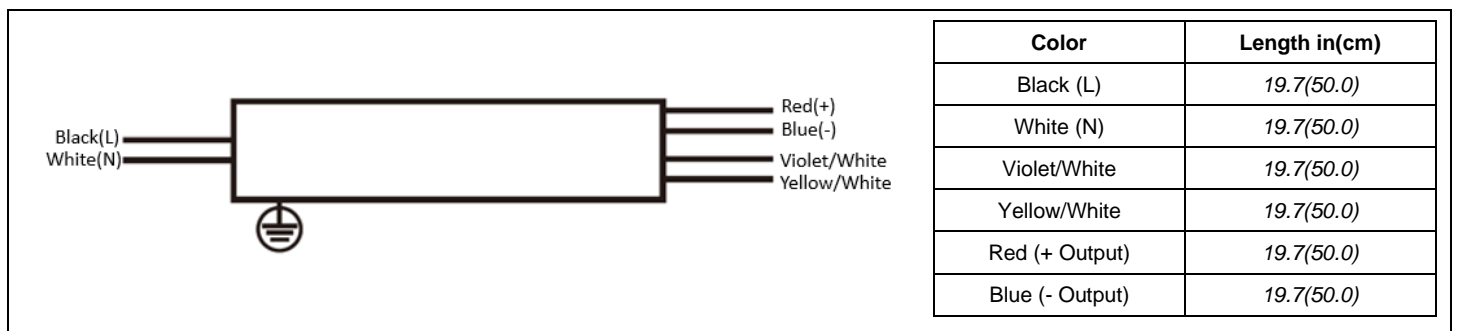

Product Features

Physical

- Unit must be installed within an electrical enclosure.
- Input wiring must be rated to 600V & 105°C or higher.
- Output wiring must be rated to 300V & 105°C or higher.

Performance

- The unit is classified as UL Class 2 as stipulated in UL8750.
- The unit is classified as Class P as stipulated in UL8750.
- Output and dimming interface are classified as Class 2 as stipulated in UL1310.
- Minimum ambient operating temperature: -30°C.
- Maximum allowable case temperature: 85°C.
- 1% Dimming depth.
- Dim to off selectable.
- For reliability and failure rate information, contact GE Current Technical Sales Representative
- The unit is UL certified for operation in dry/damp locations.
- The unit is tolerant of extended open circuit and short circuit conditions.
- The unit is compliant to FCC Title 47 Part 15 Class A.
- The unit is resistant to surges as Per IEC61000-4-5 (2kV/1KA).

UL Conditions of Acceptability – E340135

- The unit has been examined to comply with Class 2 Output Criteria.
- The unit is only to be used in dry or damp locations.
- The metal casing must be connected to EARTH.

Technical Information

90W: GED90MCV2P1750P

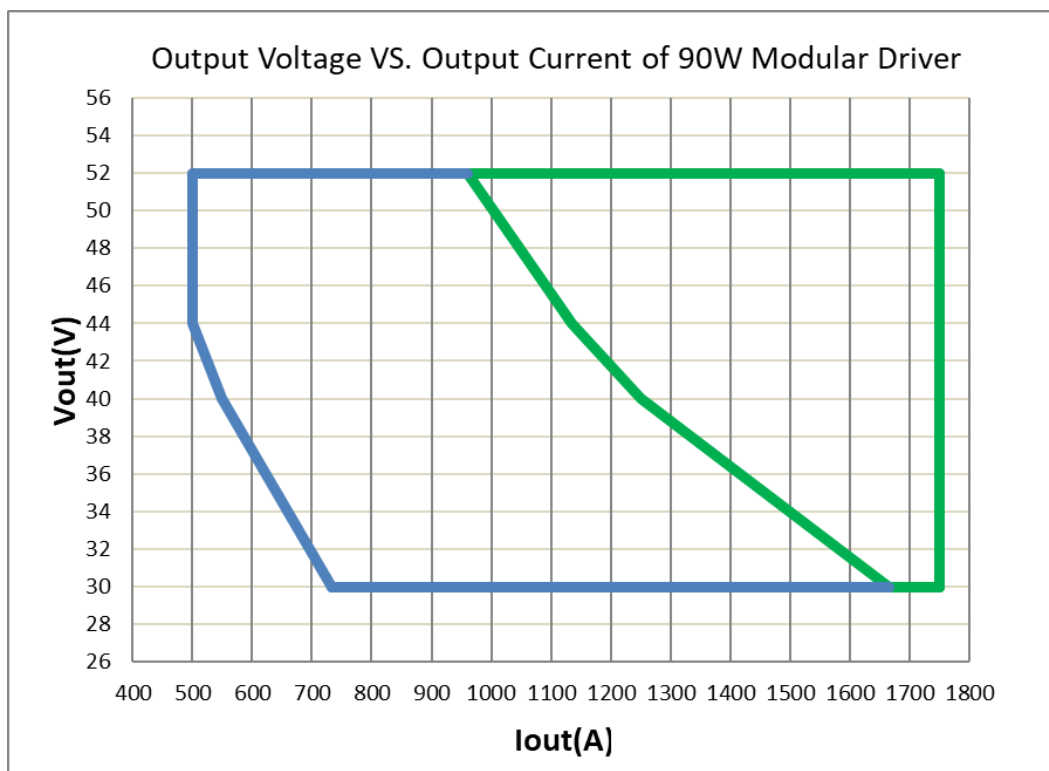

Green: Operation Window (PF>0.9, THD<20%, 1% dimming depth)

Blue: Driver can work within this window, but not ensure 1% dimming depth

Note:

- The operation window is tested at room temperature-25degC.
- Vout window(30V-52V) refers to the whole temperature range and all operating condition. $V_{out} \geq 30V$ at dimming condition and $V_{out} \leq 52V$ even at $-30^{\circ}C$.
- In any condition, LED load voltage should not less than 30V to achieve 1% dimming depth.

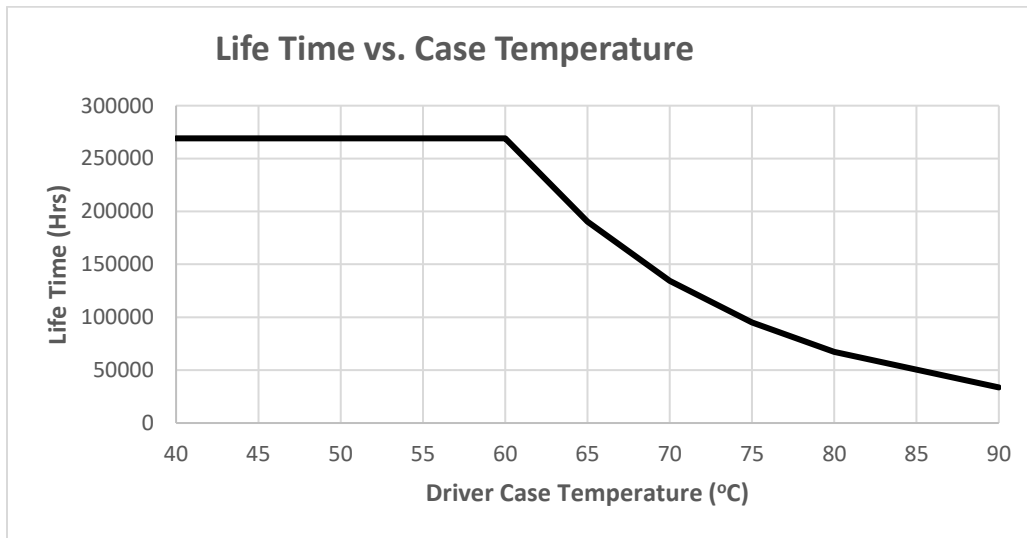

0-10V DIMMING: GED90MCV2P1750P

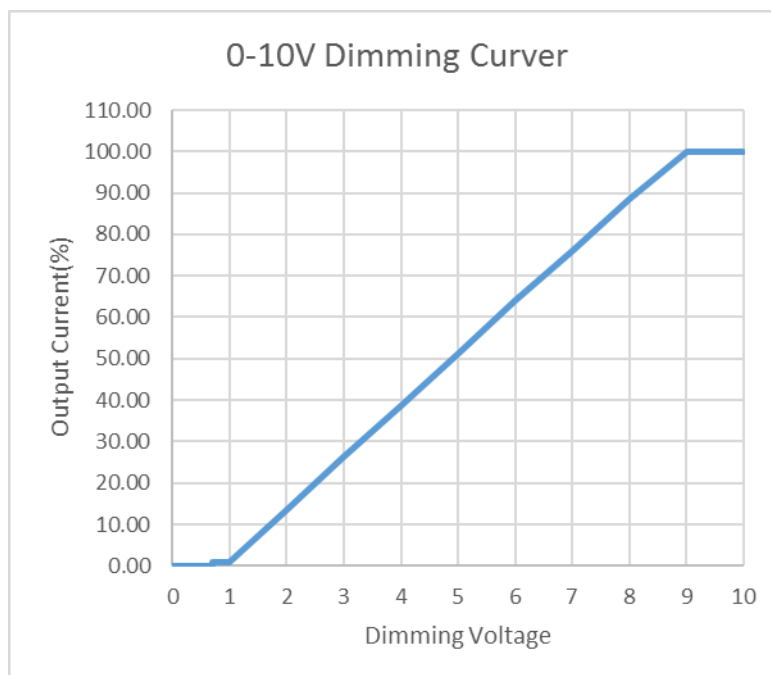

Dim-to-Off Function

Symbol	Parameter	Min	Typical	Max	Unit
Von	Turn on threshold	0.60	0.7	0.8	V
Voff	Turn off threshold	0.3	0.40	0.5	V
Ton	Turn on time	-	-	250	ms
Toff	Turn off time	-	-	1000	ms

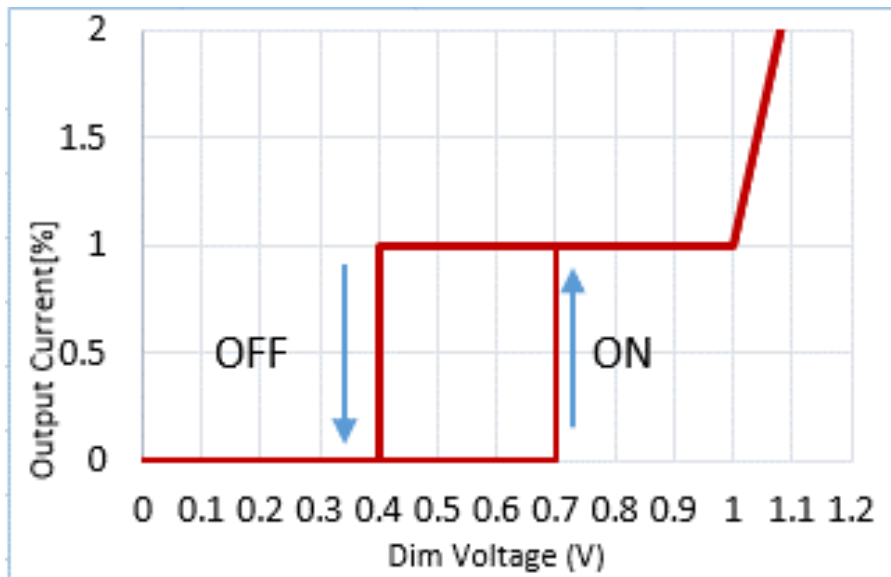

90W modular driver: GED90MCV2P1750P

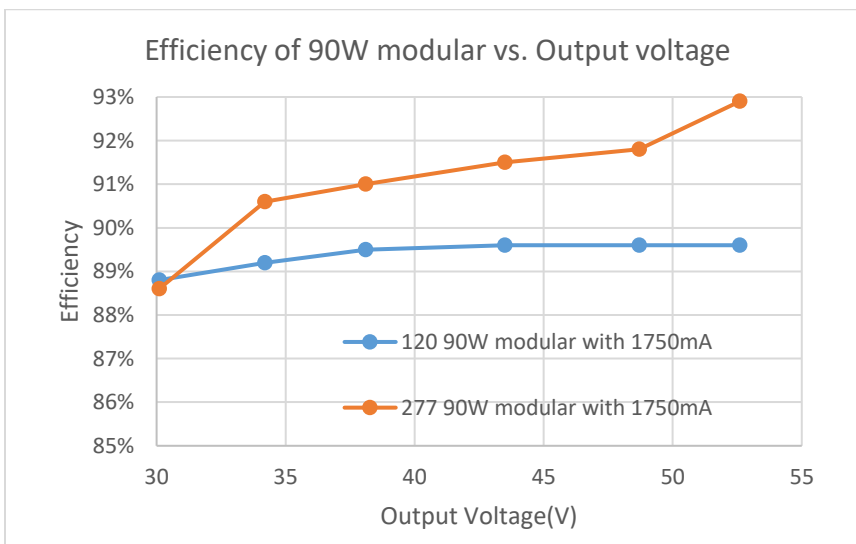
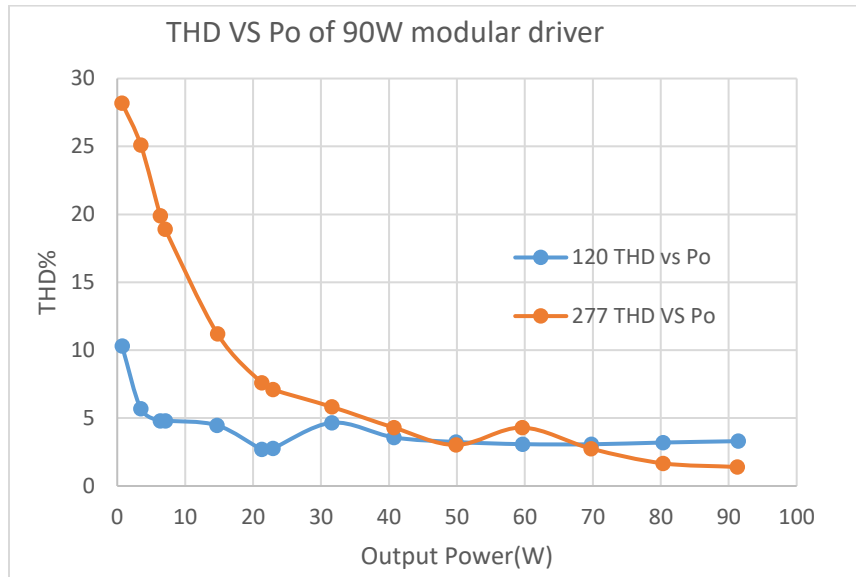
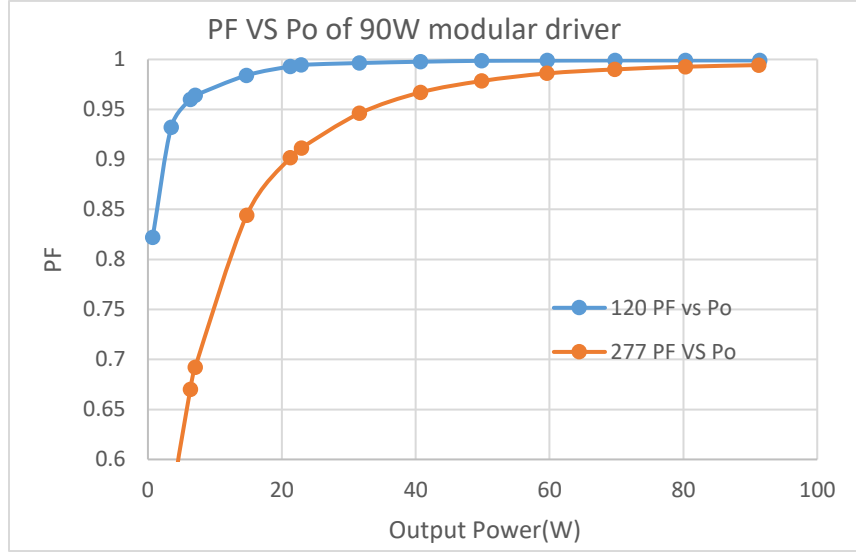

Inrush current

Input Inrush Current		
Input Voltage	Peak Current Pulse	Pulse Duration (50% of Peak)
Vrms	(A)	(uS)
120	21.4A	242.20
277	51.4A	240.30

Input Ground Leakage Current

Input Voltage Vrms (V)	Leakage Current (uA)
120	290
277	680

Mechanical dimensions

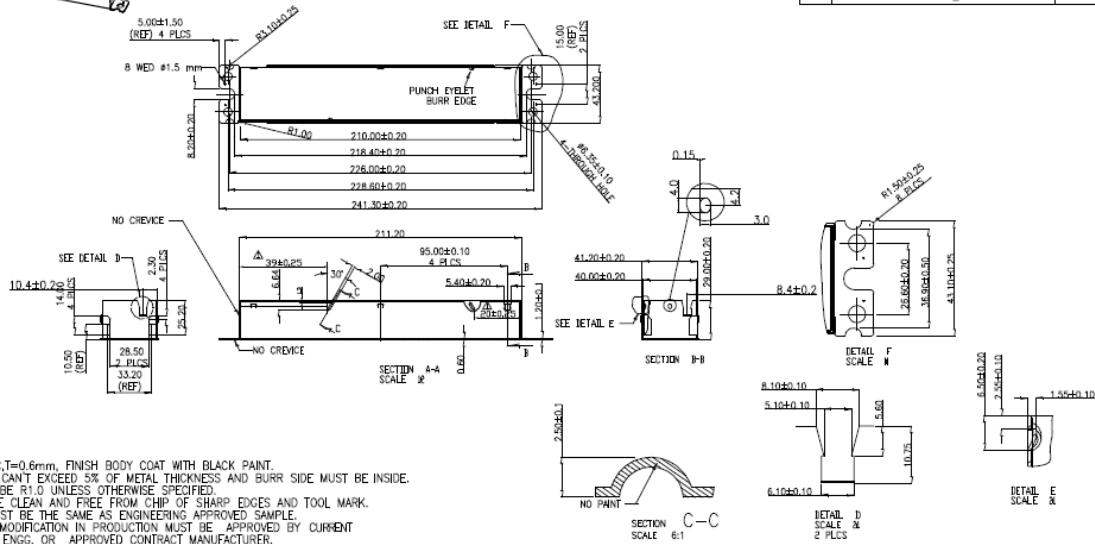
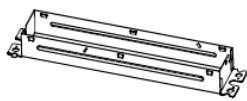

REVISIONS		
REV	DESCRIPTION	DATE
1	Create new spec	2018/10/10
1.1	Size of grounding wire changed	2019/8/19

NOTES:

1. MATERIAL-SPCC,T=0.6mm. FINISH BODY COAT WITH BLACK PAINT.
2. BURR HEIGHT CANT EXCEED 5% OF METAL THICKNESS AND BURR SIDE MUST BE INSIDE.
3. ALL RADII TO BE R1.0 UNLESS OTHERWISE SPECIFIED.
4. PART MUST BE CLEAN AND FREE FROM CHIP OF SHARP EDGES AND TOOL MARK.
5. PRODUCTS MUST BE THE SAME AS ENGINEERING APPROVED SAMPLE.
6. ANY TOOLING MODIFICATION IN PRODUCTION MUST BE APPROVED BY CURRENT ELECTRONICS ENGG. OR APPROVED CONTRACT MANUFACTURER.
7. ARTICLE OR MATERIAL MUST CONFORM TO RoHS PROCEDURE S1900000 SEC.13
8. PART MUST CONFORM TO S1900000 SECTION 4 TOXICITY PROCEDURE

Product Label

GED90MCV2P1750P

8 inch

1.5 inch

REV 1

UltraMax™
Programmable
LED Driver
GED90MCV2P1750P
SAP:93126632
PC:19380

INPUT
Voltage: 120-277 VAC, 50/60 Hz per UL
Current: 0.56 Amps per UL
PF>0.9

OUTPUT
36-120VAC Max
1750mA Max Output
9Watts

120-277V
0-10V Dimming LED Driver
Min Start Temp: -30°C
Tc=+5°C Max
Class 2
FCC Part 15 Non-Consumer
CAN ICES 005(A)/NMB-005(A)
High Power Factor
Sound Rated A
For Connections Use Wire Rated for
at Least 90°C (194°F)
Install and Ground per National
Electric Code
For Dry or Damp Locations

Made in China, Designed & Distributed
by GE Current, a Division company
Nob. Park, Cleveland, Ohio 44112
Date: _____
Firmware: _____

UL
LISTED
LED DRIVER
E440135

For assistance call:
1-800-327-0097

Class 2 Power Supply

BLACK
WHITE

RED (+)
GREEN (-)
YELLOW/WHITE (+)
YELLOW/WHITE (-)

19380

UL
LISTED
LED DRIVER
E440135

4 inch

3 inch

REV 1

GED90MCV2P1750P
SAP:93126632
PC:19380

UltraMax™
Programmable
LED Driver

LED Driver, 90W, Multivolt Input, 1750mA
Programmable, 0-10V Dimming
North America
Country of Origin: China
Voltage: 120-277V

QTY: 10

Date: _____
Firmware: _____

UL
LISTED
LED DRIVER
E440135

19380