

# LEDSAL LED SOLAR AREA LIGHT | ALL-IN-ONE DESIGN



## go completely off-grid



- 8W replaces up to 100W MH, 30W replaces up to 250W MH
- All-in-one design, the solar panel and battery are built right into the LED fixture
- No need for trenching or wiring, this fixture does not connect to any power feed
- Perfect for greenspace and greenway lighting, parks, parking lots, transit shelters and stops
- Long life battery lasts three nights with a one day charge
- Advanced new LiFePO4 battery lasts at least 2000 charge cycles
- Fixture turns on at night automatically and can be set to either stay at 100% light output or dim down if there is no motion (to extend battery life)

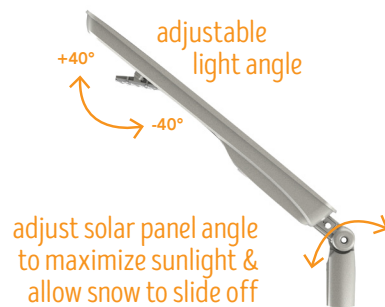

motion sensor and time control are programmable via remote



PART #	UPC	REPLACES	W	LUMENS	LPW	CCT (K)
RP-SAL-8W-50K-SF-GY-G1	844006011277	UP TO 75W HID	8	1600	200	5000
RP-SAL-30W-50K-SF-GY-G1	844006011260	UP TO 250W HID	30	6000	200	5000

\*See page 2 configurable specification sheet for additional styles, lumen packages, color temperatures and options.

**RemPhos** by Light Efficient Design  
lighting on target

FOR LIGHT EFFICIENT DESIGN PRODUCT INFO CALL Light Efficient Design, a division of TADD, LLC • 188 S. Northwest Highway • Cary, IL • 60013 • 847.380.3540 • led-llc.com  
FOR REMPHOS PRODUCT INFO CALL RemPhos by Light Efficient Design • 30 Log Bridge Road, Building 200 • Middleton, MA 01949 • 877.997.3674 • remphos.com

05.03.18 Information is subject to change without notice.

# LEDSAL LED SOLAR AREA LIGHT | ALL-IN-ONE DESIGN



## PART NUMBER BUILDER

MFR	PRODUCT	WATTAGE	COLOR	BRACKET	HOUSING COLOR	GEN
RP	SAL		50K	SF	GY	G1

8W  
30W

SF=adjustable slip-fitter bracket GY=Grey  
See ordering guide for optional brackets purchased as separate line items

### ORDERING EXAMPLE

RP-SAL-8W-50K-SF-GY-G1

## ORDERING GUIDE

CASE QTY	QUICK SHIP	DLC	REMPHOS PART #	QUICK SHIP UPC CODE	LUMEN OUTPUT (LM)	WATTAGE (W)	LPW	WARRANTY (YRS)	RECOMMENDED MOUNTING HEIGHT (FT)
1	●	N/A	RP-SAL-8W-50K-SF-GY-G1	844006011277	1600	8	200	5	UP TO 15FT
1	●	N/A	RP-SAL-30W-50K-SF-GY-G1	844006011260	6000	30	200	5	UP TO 30FT

ACCESSORIES

REMPHOS PART #	DESCRIPTION
RP-SAL-BKT-8W-RP-G1	Round pole bracket for 8W
RP-SAL-BKT-8W-SP-G1	Square pole bracket for 8W
RP-SAL-BKT-8W-TN-G1	Trunnion bracket for 8W
RP-SAL-BKT-30W-RP-G1	Round pole bracket for 30W
RP-SAL-BKT-30W-SP-G1	Square pole bracket for 30W
RP-SAL-BKT-30W-TN-G1	Trunnion bracket for 30W
RP-SAL-REMOTE-G1	RP-SAL-REMOTE-G1 (remote is included standard with each fixture ordered)



Adjustable Slip-Fitter Bracket (SF)



Round Pole Bracket (RP)



Square Pole Bracket (SP)



Trunnion Bracket (TN)

## PHOTOMETRICS

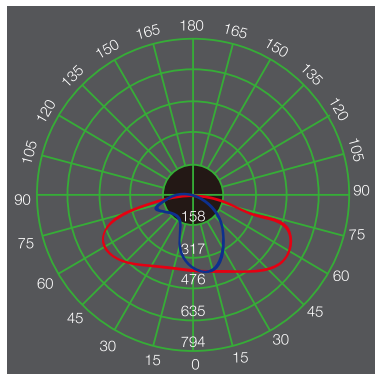

**8W**  
Replaces up to 75W HID

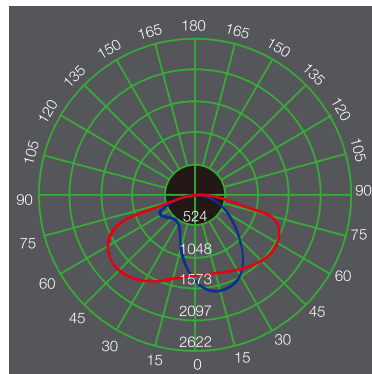

**30W**  
Replaces up to 250W HID

**RemPhos** by Light Efficient Design  
lighting on target

FOR LIGHT EFFICIENT DESIGN PRODUCT INFO CALL Light Efficient Design, a division of TADD, LLC • 188 S. Northwest Highway • Cary, IL • 60013 • 847.380.3540 • led-llc.com  
FOR REMPHOS PRODUCT INFO CALL RemPhos by Light Efficient Design • 30 Log Bridge Road, Building 200 • Middleton, MA 01949 • 877.997.3674 • remphos.com

05.03.18 Information is subject to change without notice.

# LEDSAL LED SOLAR AREA LIGHT | ALL-IN-ONE DESIGN

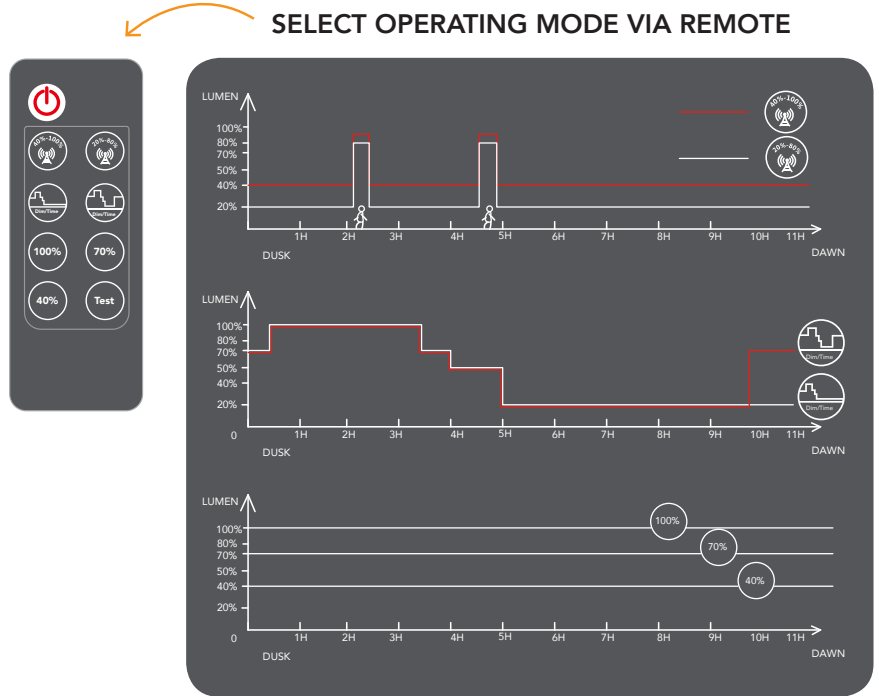
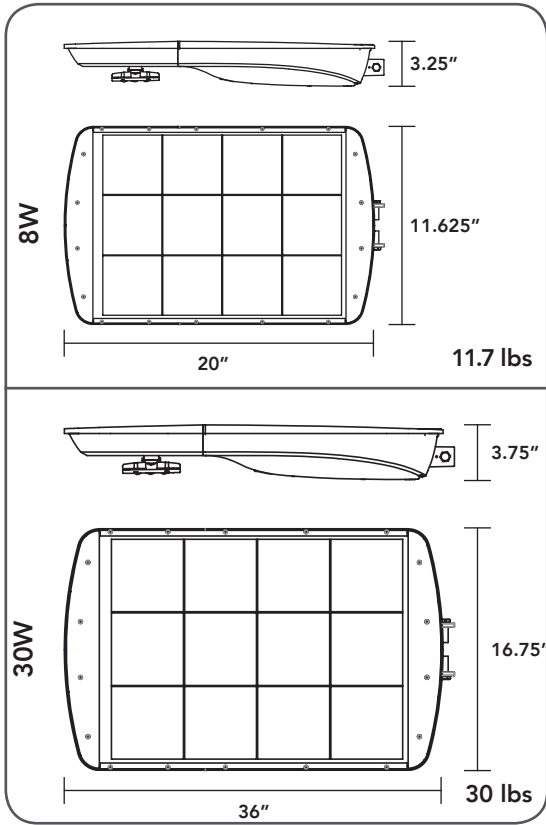

SEE INSTRUCTION MANUAL FOR MORE DETAILS ON THE AVAILABLE PROGRAMS

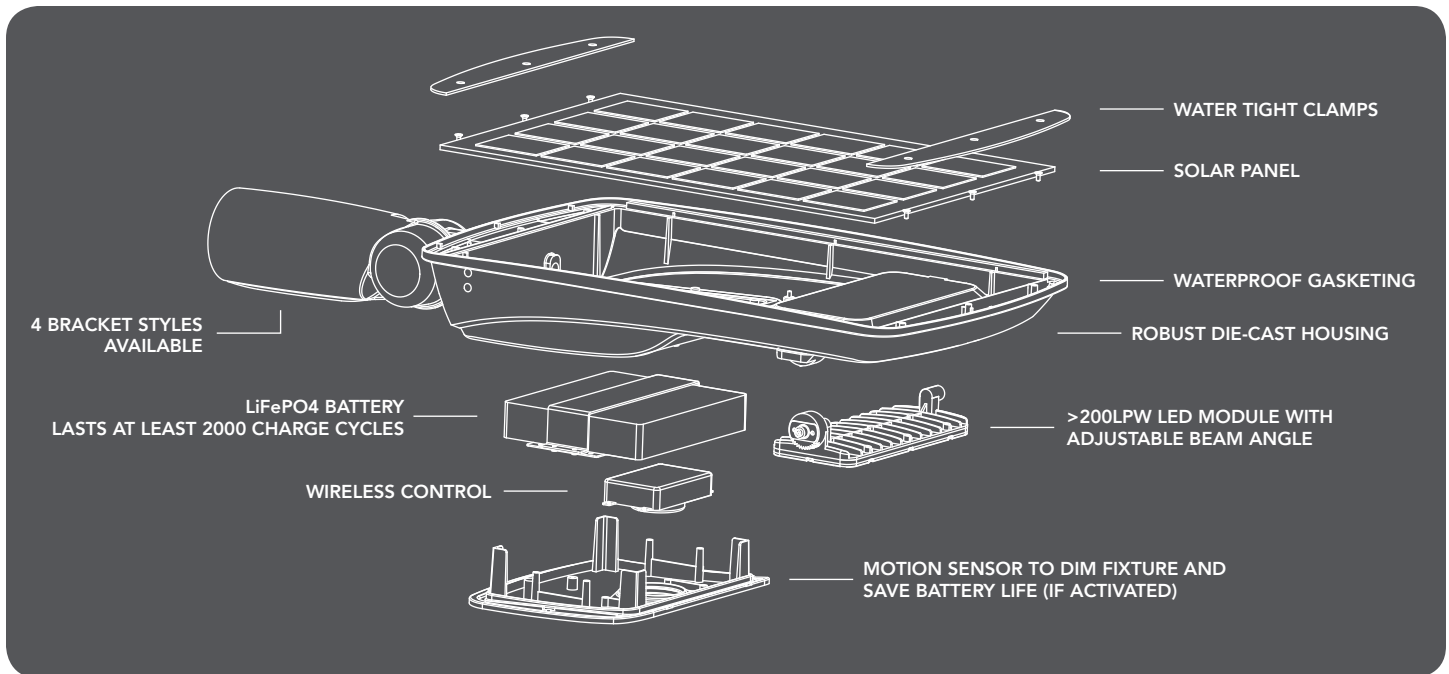

**RemPhos** by Light Efficient Design  
lighting on target

FOR LIGHT EFFICIENT DESIGN PRODUCT INFO CALL Light Efficient Design, a division of TADD, LLC • 188 S. Northwest Highway • Cary, IL • 60013 • 847.380.3540 • led-llc.com  
FOR REMPHOS PRODUCT INFO CALL RemPhos by Light Efficient Design • 30 Log Bridge Road, Building 200 • Middleton, MA 01949 • 877.997.3674 • remphos.com

05.03.18 Information is subject to change without notice.