

**PHILIPS
ADVANCE**

LED Driver

Xitanium

20W 0.4-0.7A 30V LE+TE INT
X1020C070V030RNP2



Class P
LED class 2 output
For Dry and Damp Location

Conforms to UL STD 8750
Certified to CAN/CSA STD
C22.2 No. 250.13

The Philips Advance Xitanium range of phase-cut dimming LED drivers are perfectly suited for commercial fittings in downlight and track lighting applications. These models offer the flexibility of precise output of drive currents from selectable settings and are compatible with a variety of electronic low voltage dimmers to deliver reliably smooth dimming performance. The drivers are offered in a compact form factor suitable for use in elegantly unobtrusive fixture designs. Rated for long life with efficient performance, these drivers are excellent design choices for LED downlight fixtures offering the benefits of long-lasting energy savings with low maintenance costs.

Specifications

Input Voltage (Vac)	Output Power (W)	Output Voltage (V)	Output Current (A)	Efficiency@ Max Load and 75°C Case	Max Case Temp. (°C)	Input Current (A)	Max. Input Power (W)	THD @ Max Load (%)	Power Factor @ Max Load	Surge Protection (Combi-Wave, KV)	Envir. Protection Rating
120	20	15 - 30	0.4 - 0.7	85	Life-75°C Max-85°C	0.2	25	<10%	>0.95	2.5	UL damp & dry
277				86		0.1		<25%			

Enclosure

	In. (mm)
Case Length	3.74 (95)
Case Width	1.57 (40)
Case Height	0.98 (25)
Mounting Length	3.35 (85)
Overall Length	

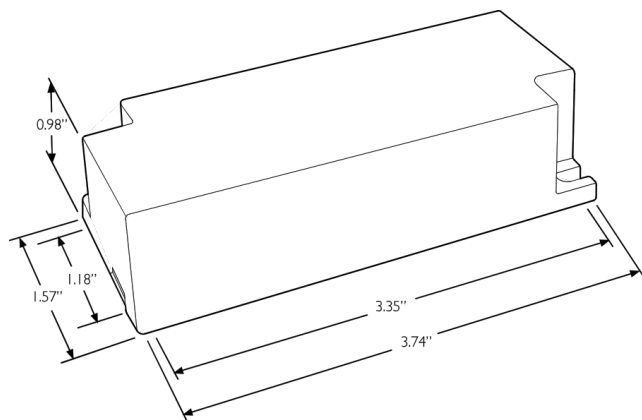

Wiring Diagram

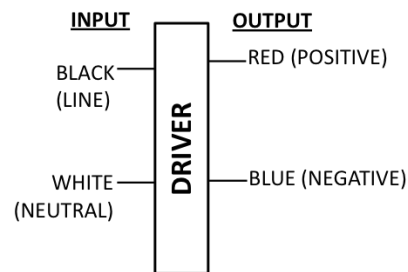

Input and output use lead wires.

Lead-wires are input 18AWG / output 22AWG 105C/600V stranded copper.

Standard lead length is 150mm (±10mm) on all wires outside the can.

All wires have tinned ends.

Dimming	Dimming Range (with specified dimmers)	Minimum Output Current (A)	Other Comments
LE + TE Leading Edge & Trailing Edge	2% ~ 100%	0.008	

Xitanium 20W 0.4-0.7A 30V LE+TE INT

Features

- 50,000+ hour lifetime¹
- UL Class 2 output with adjustable drive current
- Leading edge/Trailing edge dimming
- Compact form factor

Benefits

- Enables easy design-in with excellent thermal performance
- Enables simple, fast, flexible application-specific configurations
- Enables light levels suited for the application
- Enables design of low-profile fixtures

Application

- Indoor downlight and track applications
- Retail, hospitality

Electrical Specifications

All the specifications are typical and at 25°C Tcase unless specified otherwise.

Product Data

Order Information	
Full Product Code	XI020C070V030RNP2M (Mid-Pack, 48pcs/Box), 12NC: 929000766113
Line Frequency	50/60Hz
Min. Mains Voltage Operational	108 Vac
Max. Mains Voltage Operational	305 Vac
Output Information	
Maximum Open Circuit Voltage	< 60Vdc
Output Current Ripple	30% max @ max Iout
Output Current Tolerance (within full output operating range)	400mA: (-10% / +5%) 500mA: (-10% / +5%) 600mA: (-8% / +5%) 700mA: (-8% / +5%) Output Current variation includes effects of line & load regulation, temperature variation and component tolerances
Protections	Short Circuit, Open Circuit Protection for LED + and LED – and Temperature Foldback
Features	
0-10V Dimming	LE + TE dimming
AOC (Adjustable Output Current)	400mA to 700mA via DIP switches (refer to figure & notes in the Electrical Specification section)
Environment & Approbation	
Operating Ambient Temp. Range	-20°C to +50°C
Max. Case Temperature (Tcase)	Max. 85°C, Tcase Life: 75°C
Agency Approbations	UL8750, UL991, CSA250.13-14, C22.2 No. 0.8-12, Class P (UL, CSA, ETL)
Electromagnetic Compliance	FCC Title 47 Part 15 Class A, CAN ICES-005 (A) / NMB-005 (A)
Audible Noise	<24dB Class A
Weight	0.27 Lbs / 0.122 kgs

1. Philips Advance Xitanium LED drivers are manufactured to engineering standards correlating to a designed and average life expectancy of 50,000 hours of operation at maximum rated case temperature. Minimum 90% survivals based on MTBF modeling.