

Project Name:	
Type:	

ZBA Wireless Control

Phase-cut and 0-10V



This innovated and multi-function wireless fixture adapter is designed to work flawlessly within any Casambi communication systems. The ZBA-E001B and ZTA-T001B can be used with one to one or one to multiple luminaries environment.

The ZBA Series not only provides wireless control to the luminaries. It also provides On/Off and versatile analog dimming controls. The wide range AC input from 110VAC to 277VAC solved the problem during field installations ZBA-T001 works from 100-240VAC. It's compact form-factor gives fixture manufactures an easier way to adapt during this designing stage. The isolated 12 or 24VDC output provides source voltages for low voltage occupancy and/ or photo sensors. Tethered with ZBA-E001B, you can turn non-wireless sensor into Casambi ready sensor to join the network.



WARRANTY

- See [Limited Warranty Policy](#) for more additional information.

SPECIFICATIONS :

	Load-Controller	Phase-cut
MODEL NUMBER	ZBA-E001B	ZBA-T001B
COMPATIBILITY :	BT, Casambi	
INPUT :	110 – 277VAC/ 50 – 60Hz	
OUTPUT VIA ISOLATED REPLY :	110 – 277VAC/ 50 – 60Hz, 10 Amps Max.	220VA
LOW VOLTAGE OUTPUT :	12 or 24VDC; 50mA	
SENSOR SUPPOT (Optional):	Occupancy Sensor Linear Sensor	N/A
OPERATING ENVIRONMENT :	-20 to +65°C	
RADIO PROPERTIES :	2.4GHz, +19.5dBm Transmit Power	
ANTENNA :	Built-in and External	
EXTERNAL ANTENNA :	Optional with connector	
DIMMING CONTROL :	0-10VDC	Phase-cut/ PMW
DIMENSIONS :	123.3 x 39 x 29mm (L x W x H)	
COMPLIANCE :	ETL/ FCC Certified	
WARRANTY :	5 YEAR	

ORDER INSTRUCTIONS :

ORDER INSTRUCTIONS	
ZBA-E001B	0-10 dimming
ZBA-T001B	Phase-cut

FIXTURES :

PROFILE #	PROFILE NAME/ IN APP DESCRIPTION	DESCRIPTION	WIRING	PHYSICAL USE/ TYPE OF DEVICE CONNECTED
29778	BTA-E001 0-10V	A 0-10V dimmer with one slider in application to control light level. Relay is OFF at 0% and ON at levels above 0%	1	1 x 0-10V Driver
29873	BTA-E001 Sensor	Acts as a presence sensor for the Casambi network together with an external PIR sensor.	2	Presence Sensor
32241	Phase-cut		3	PWM

Project Name:	
Type:	

ZBA Wireless Control

Phase-cut and 0-10V



WIRING DIAGRAM :

Wiring 1: 0-10V

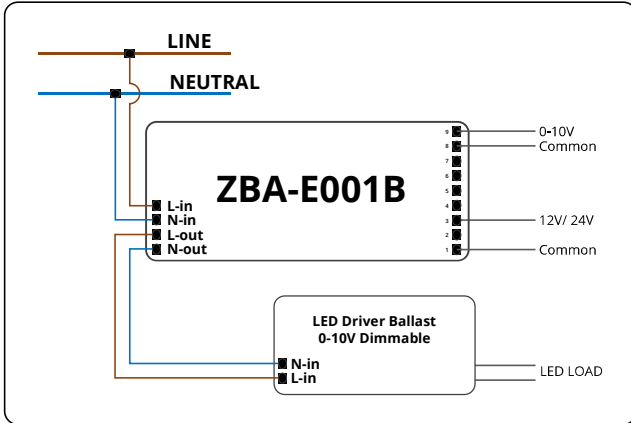

Wiring 2: Sensor

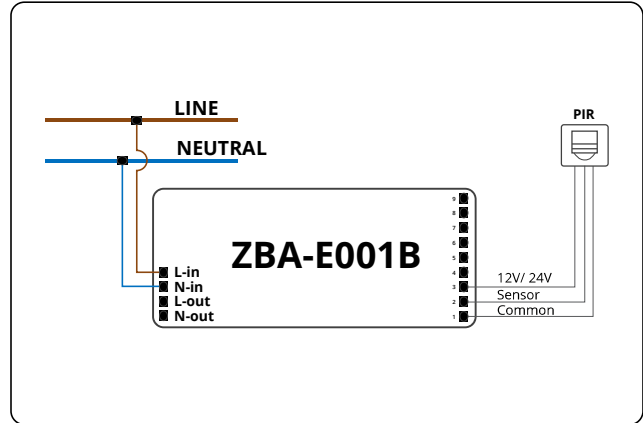

Wiring 3: Phase-cut

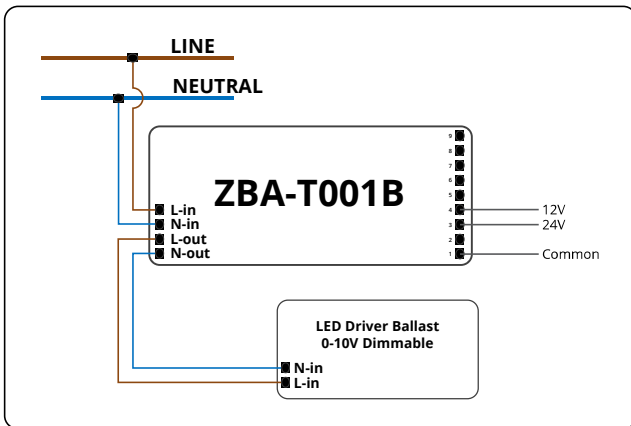

MECHANICAL DRAWING :

